



Two-stroke
marine
systems

Power into the future

MAN Energy Solutions
Future in the making

**MAN B&W
ME-LGIP:
the world's first
dual-fuel LPG
marine engine**



Future in the making

MAN Energy Solutions is the world's leading provider of large-bore diesel engines, turbomachinery, and integrated power systems. We make four-stroke and two-stroke engines for marine and stationary applications, turbochargers and propellers, gas and steam turbines, compressors and chemical reactors.

Our marine systems expertise is focused on emission reduction, complete propulsion packages, electrical propulsion, dual-fuel, LPG, and digitized services.

In the competitive field of ocean transport with its fluctuating fuel prices, we offer cost-effective propulsion systems that comply with all emission legislations and meet strict safety requirements.

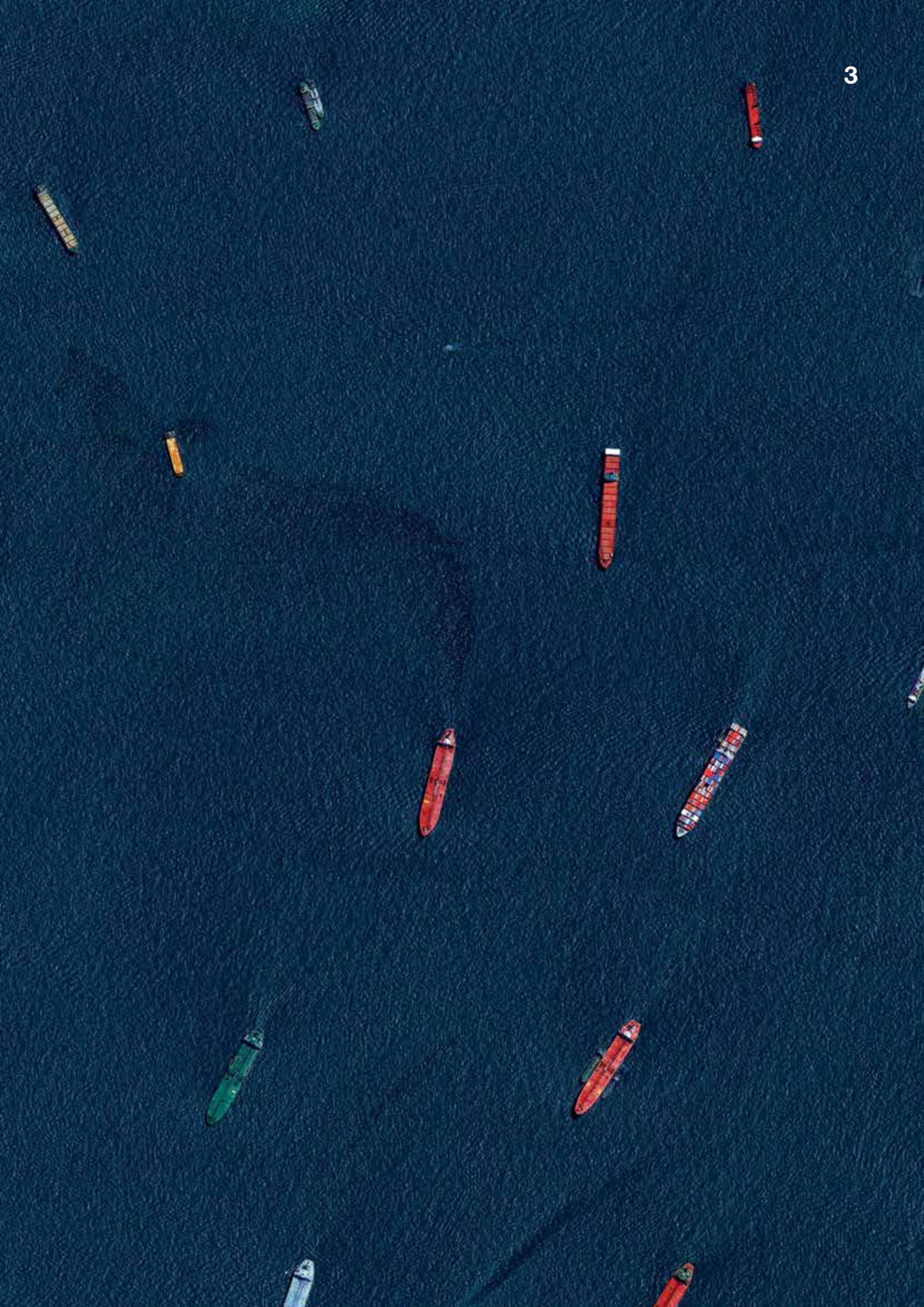

Build certainty into your investments

New emissions regulations and rising fuel costs have thrown the world of ocean transport into uncertainty. If you are investing in the future with new ship orders or upgrades, this can have a major impact on your strategy.

The new MAN B&W ME-LGIP dual-fuel LPG marine engine de-risks your investments and gives you back control. By switching to LPG, you achieve full compliance with all upcoming SO_x regulations, and get a competitive edge of 13% - 18% less CO₂ emissions with no loss of performance or efficiency. You also retain the flexibility to use conventional fuels to take advantage of optimal market prices.

Beyond compliance and flexibility, LPG also offers lower total cost of ownership, giving you a competitive edge at a time of uncertainty. Our unique liquid gas injection technology can also be applied as a simple retrofit solution, helping you to maximize value from your existing fleet.





Dual-fuel
means
operational
security



Compliance

LPG is a zero-sulphur fuel with relatively lower carbon content, which helps you achieve full compliance with IMO 2020 SO_x regulations and is an important step to reach the 2050 IMO GHG targets. LPG also gives credit towards your IMO EEDI compliance requirements.

Cost

LPG gives you greater financial security; it is traditionally priced similar to HFO, and thereby cheaper than MGO, yet delivers the same performance and efficiency. Using our dual-fuel engine technology, you can also take advantage of fluctuating fuel prices in the future. Importantly, the ability to use LPG cargo as a supplement fuel source provides significant cost savings for LPGC owners or charterers, including reduced time and fees for fuel bunkering.

Continuity

Switching to LPG also helps to support operational continuity. As a widespread energy source, availability is high and LPG is easier to store and handle, compared with cryogenic gaseous fuels. Lastly, by ensuring your fleet is compliant in all international waters, you eliminate any risk of disruptions (and potential port fines) to your global shipping schedule.

MAN B&W **Reliable, efficient and flexible** ME-LGIP



The innovative new MAN B&W ME-LGIP is the world's first and only dual-fuel LPG two-stroke marine engine. Building on MAN's proven legacy for excellence in dual-fuel and two-stroke technology, the engine sets new standards for flexibility, fuel efficiency and operational simplicity.

The MAN B&W ME-LGIP is the only liquid gas injection dual-fuel two-stroke engine on the market, allowing you to switch between VLSFO, MGO and LPG fuels with no loss to performance. Not only does this help to maximize ROI, but with zero sulphur in LPG and 13% - 18% less CO₂ from LPG fuel, you stay comfortably within emissions limits.

Engineered to MAN's uncompromising quality standards, the MAN B&W ME-LGIP also delivers the long-term reliability you need, with simple installation and minimal maintenance requirements. As with all our marine engine portfolio, the engine features fully automated safety, control and monitoring systems through our widely-known, intuitive interface.

An ideal retrofit solution

Our compact liquid gas injection system means the MAN B&W ME-LGIP could also be an ideal retrofit solution for your existing fleet. The technology can be applied to all types of ships with an ME-C engine of bore size 35, 50, 60 and 70 bore. LPG gas carriers are likely retrofit candidates. As of Q1 2021, 4 VLGS has been converted to LGIP, and another 11 more VLGC's are awaiting conversion to LGIP propulsion.

Committed to the future

At MAN we are continually investing in new ways to drive excellence across the worldwide marine sector. Our commitment to research, development and to our customers means we will always be by your side with global, tailored service and support, including training for your staff and crew with remote service options and through our Global Academy Network.



Proven fuel for a proven platform

- Reliability confirmed by service experience from 5500 ME-type engines
- Specified maximum continuous power range from 4,350 kW to 29,120 kW
- Gaseous fuel injection technology and engine performance verified on verified on more than 1.7 million dual fuel running hours as of Q1 2021.

Our range of ME-engines for low-flashpoint fuels includes:

- ME-GI (methane)
 - ME-GIE (ethane)
 - ME-LGIM (methanol)
 - ME-GA (methane)
 - ME-LGIP (LPG)
-

MAN B&W Specifications ME-LGIP



Comparison of fuel consumption

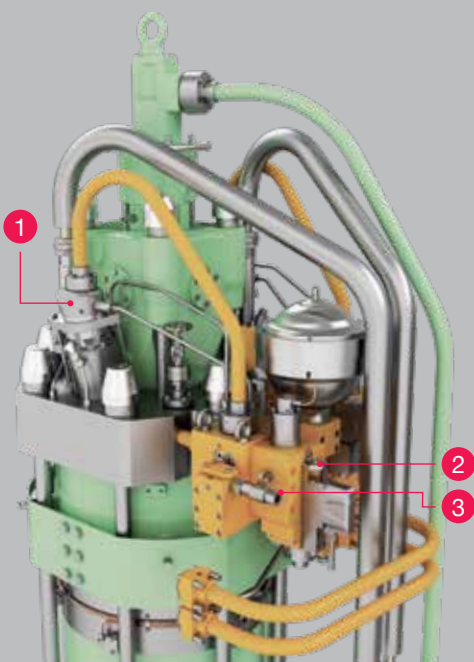
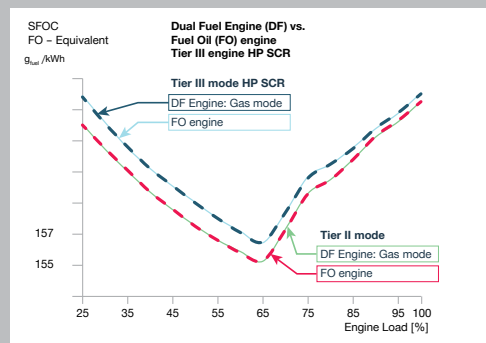

Cylinder cover with LPG injection valve and gas block

- 1 LPG injection valve
- 2 ELGI valve (injection timing)
- 3 ELWI valve (fuel pressurization)

General

- Engine cycle: two-stroke
- Number of cylinders: 5 to 8 depending on bore size
- Bore: 350, 500, 600 and 700 mm
- Stroke/bore ratio: 4.0 to 4.65

Fuel consumption at part load optimization

- Same heat rate on fuel oil and LPG
- 80% MEP derated engine at 65% load:
 - G60ME-LGIP: 155 g/kWh
 - G50ME-LGIP: 154 g/kWh

MEP and speed derating

- Large layout area
- G60ME-LGIP: 56% power derating possible
- Multiple choice of engine size and number of cylinders to match optimum propeller design and power

Compliance with emission regulations

- IMO Tier II
- IMO Tier III (with SCR, EGR or EcoEGR*)
*for improved efficiency when operating in Tier II mode

Main features

- **Turbocharging system**
High efficiency constant pressure turbocharging systems with MAN, ABB or MHI turbochargers as standard
- **Engine automation and control**
In-house developed gas safety and control system
- **Fuel oil system**
Common injection system for pilot oil and for main injection
- **Gas system**
LPG injection by fuel booster injection valves (FBIV)
- **Tolerant to many different LPG compositions**

Auxilliary systems

- Gas supply conditions: circulation with supply at 50 +/- 2 bar and 25-55 deg. C

MCR = Maximum Continuous Rating
SCR = Selective Catalytic Reduction
SFOC = Specific Fuel Oil Consumption

MAN PrimeServ

Service with passion





24

hours a day



365

days a year

MAN PrimeServ is the dedicated MAN Energy Solutions service brand. Via a network of over 100 service centers worldwide, MAN PrimeServ provides 24/7 service across the globe. Our range of services includes technical support, consulting and OEM spares, as well as maintenance, repair and comprehensive individualized service plans.

MAN PrimeServ's aim is to provide

- Prompt delivery of high-demand OEM spare parts within 24 hours
- Fast, reliable and competent customer support
- Individually tailored O&M contracts
- Ongoing training and qualification of operators and maintenance staff
- Global service, 24 hours a day, 365 days a year
- Diagnosis and troubleshooting with our high-performance Online Service

Worldwide service

We offer retrofitting and upgrade services to bring engines and turbochargers already in service up to the very latest standards of performance and efficiency.

Using the latest digital technology, we enable you to maximize the performance and availability of your MAN equipment by accessing real-time data analysis, remote support and rapid solutions. We also offer an extensive range of training courses at MAN PrimeServ academies around the world.

Our service does not vary according to location. We know that a vessel may be built in Asia, operated in Europe for ten years and then move to Africa for the next ten years. That does not alter our focus on dedicated training, fast delivery of strategic spare parts, a comprehensive approach, or our tailored maintenance contracts.

For more information please visit
www.man-es.com/primeserv



100

Service centers
worldwide



MAN Energy Solutions

2450 Copenhagen SV, Denmark

P + 45 33 85 11 00

F + 45 33 85 10 49

info-cph@man-es.com

www.man-es.com

All data provided in this document is non-binding. This data serves informational purposes only and is not guaranteed in any way. Depending on the subsequent specific individual projects, the relevant data may be subject to changes and will be assessed and determined individually for each project. This will depend on the particular characteristics of each individual project, especially specific site and operational conditions.

Copyright © MAN Energy Solutions.
1510-0286-00ppr May 2021
GGKM-CPH-0521