



Efficiency of MAN B&W two-stroke engines

MAN Energy Solutions
Future in the making

Stationary application

Future in the making



Contents

| | |
|--|----|
| Definitions | 05 |
| Measuring heating values | 06 |
| Engine and generator heat rates and efficiency | 07 |
| Power consumption in auxiliary systems | 09 |
| Thermal efficiency | 10 |
| Engine control | 12 |
| Installation planning | 12 |
| References | 13 |
| Abbreviations (Definitions) | 13 |

The purpose of this paper is to describe various terms used in connection with the installation of MAN B&W two-stroke low-speed diesel engines for stationary application, as there are differences compared to engines installed in vessels.

MAN B&W two-stroke low-speed stationary engines

MAN Energy Solutions designs MAN B&W two-stroke low-speed diesel engines with a focus on continuous development to meet customers' requirements in the following target areas:

- Highest fuel efficiency
- Low maintenance costs
- High reliability

- Operational flexibility – from base load to standby
- Wide scope for thermal energy recovery
- Modular concept for flexible capacity expansion
- Wide fuel flexibility
- Insensitivity to high ambient temperatures and high-altitude locations

The engines we design are characterised by robustness, reliability,

simple operation and easy maintenance, preconditions for achieving an availability of more than 8,000 hours per year.

Our business concept is that MAN Energy Solutions in Copenhagen develops and designs these engines for both marine and stationary application.

Our licensees located worldwide handle production and sale.

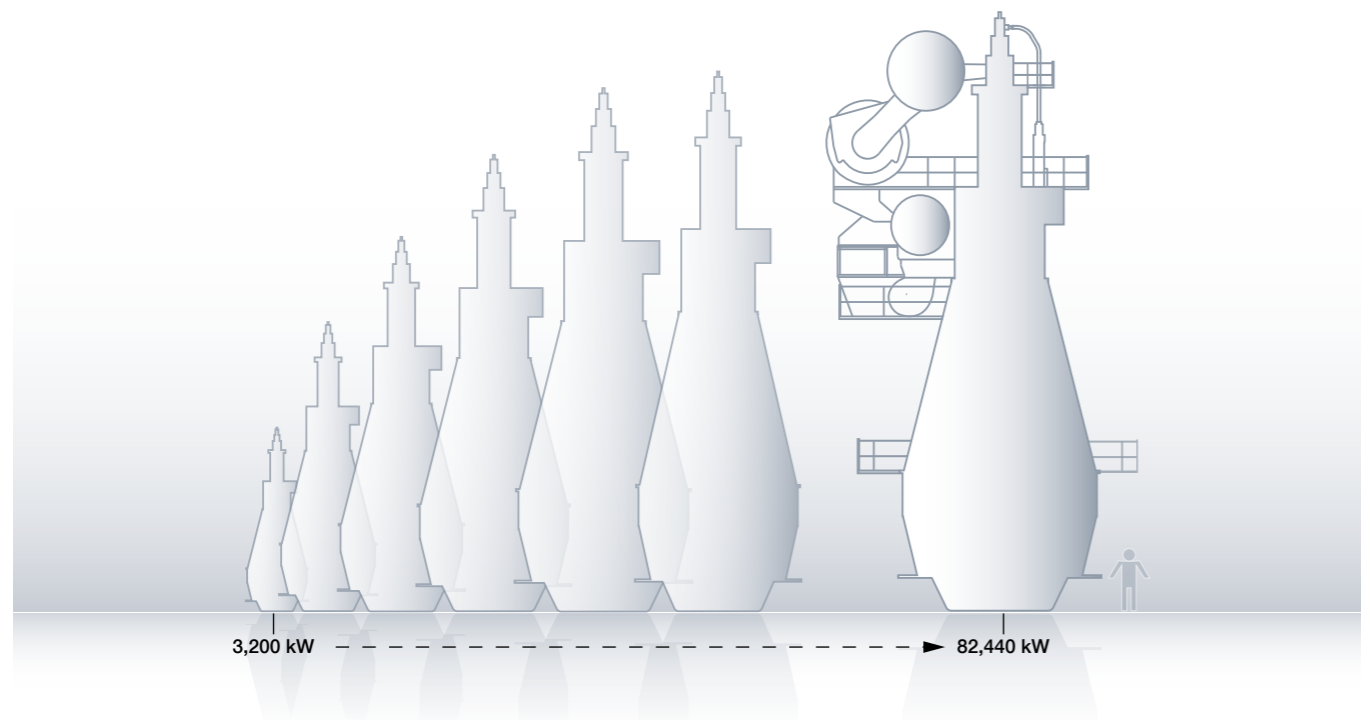

Fig. 1: Overview of our stationary engine programme

Efficiency of MAN B&W two-stroke engines

Stationary application

Definitions

MAN B&W two-stroke low-speed diesel engines are designed to provide optimum fuel flexibility and are an ideal source of power, whether operating on gas, liquid fuel or liquid bio fuel. Liquid fuels are HFO, diesel, some types of crude biofuel and crude oil. Gaseous fuels are natural gas and ethane. Liquid gas fuels are LPG, DME, methanol and ethanol.

Engine heat rate

The data specified in the "MAN B&W Stationary Engine Programme" refers to mechanical output under ISO

3046/1-2002 ambient conditions, which are:

- Compressor inlet temperature 25°C
- Compressor inlet pressure 1000 mbar
- Charge-air inlet coolant temperature 25°C

For other ambient conditions please contact MAN Energy Solutions in Copenhagen.

Fuel consumption

The engine heat rate informed by MAN Energy Solutions is subject to a tolerance of ±5% at MCR under ISO

3046/1-2002 ambient conditions. For other ambient conditions, and for engines with emission control, TCS and/or BCST, please contact MAN Energy Solutions in Copenhagen for a calculation of the expected fuel consumption.

Technical data, such as power, speed and gross efficiency of the ME-S, ME-GI-S and ME-LGI-S type engines are the same as for the corresponding MC-S engines. MAN Energy Solutions in Copenhagen can provide the technical engine data for your specific project, including project-specific emission requirements.

Operating mode

Stationary engines operate at load patterns and ambient conditions which differ from those of their marine counterparts. This is illustrated in Figs. 2 and 3, showing the typical operating conditions for both applications.

Fig. 2 shows that for stationary engines the average load is 95-100% during 8,000 hours or more per year in operation, whereas for marine engines the average load is around 60-80% and, furthermore, often only for 6,000 hours per year in operation. This means that stationary engines typically have a load factor which is more than 25% higher than that of marine engines. In 2016, the load on a general marine engine installation is currently closer to 60%.

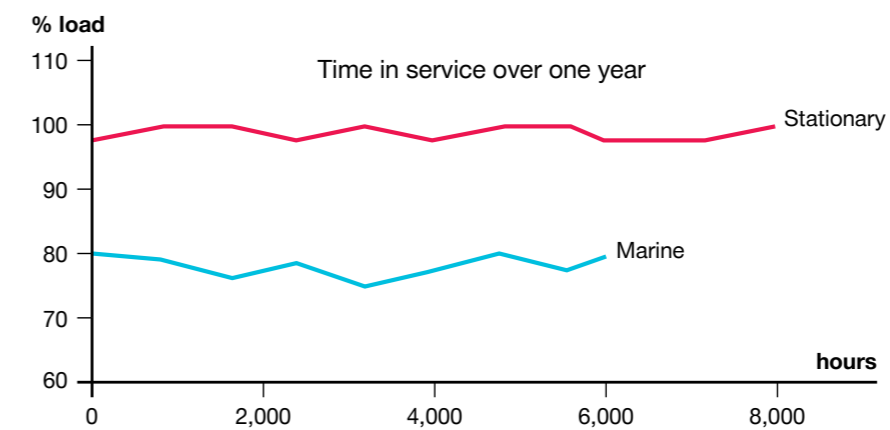

Fig. 2: Typical load profiles during a year in operation

| Ambient conditions | Unit | Stationary engines | | Marine engines | | |
|---------------------------|------|--------------------------------------|---|-------------------------------------|----------|--------|
| | | High yearly site-climatic conditions | Design | Low yearly site-climatic conditions | Tropical | Design |
| Cooling water temp. | °C | 51 | Yearly climatic conditions on site; design average chosen by MAN Energi Solutions | 6 | 32 | 25 |
| Air inlet temp. | °C | 50 | Yearly climatic conditions on site; design average chosen by MAN Energi Solutions | -20 | 45 | 25 |
| Compressor inlet pressure | mbar | 1,013 | Depends on height above sea level | 930 | 1,000 | 1,000 |

Fig. 3: Ambient conditions

As indicated in Fig. 3, stationary engines are exposed to greatly-varying ambient conditions prevailing at site, for example higher and lower air- and cooling-water temperatures. Furthermore, stationary engines are frequently exposed to fuel oils of non-marine quality. The fuel is often delivered by one permanent supplier, meaning that the quality from this supplier, good or bad, will prevail. Therefore, lube oils, especially cylinder lube oils, have to be individually selected and, at times, even individually specified and optimised in order to match the fuel oil available.

Similarly, the gas supply is also subject to non-marine quality.

Heat rate versus specific fuel consumption

In some industries fuel consumption is typically stated in terms of g/kWh, based upon a standard fuel with a lower calorific value (LCV) of 42.7 MJ/kg. For stationary application the equivalent term “heat rate” is used, which is normally expressed in kJ/kWh.

The heat rate indicates the amount of energy required to generate one unit of shaft power. By using this term the heat rate value remains the same independent of the LCV of the fuel.

Engine programme values can be converted by application of the ISO LCV of the fuel, for example 42,700 kJ/kg, applying the following relation:

$$FC [g/kWh] = \frac{\text{Heat Rate [kJ/kWh]} \times 1000}{LCV [kJ/kg]}$$

The actual fuel consumption can be estimated using the site specific actual heat rate and LCV.

Difference between HCV and LCV

The heat of combustion for fuels can be defined either by higher calorific value or lower calorific value.

– Higher calorific value

The quantity known as higher calorific value (HCV) (or “gross energy” or “upper heating value” or “higher heating value” (HHV)) is determined by bringing all products of combustion back to the original pre-combustion temperature and, in particular, by condensing any water vapour produced. Such measurements often use a standard temperature of 25°C.

This is the same as the thermodynamic heat of combustion since the enthalpy change for the reaction assumes a common temperature of the compounds before and after combustion, in which case the water produced by combustion is liquid. In other words, HCV assumes that all the water components are in liquid state at the end of combustion (in products of combustion) and that heat below 150°C can be put to use.

– Lower calorific value

The quantity known as lower calorific value (LCV) (or “net calorific value” (NCV) or “lower heating value” (LHV)) is determined by subtracting the heat of vaporisation of water vapour from the higher heating value. This treats any H₂O formed as a vapour.

The LCV assumes that the latent heat of vaporisation of water in the fuel and the reaction products are not recovered. It is useful when comparing fuels where condensation of the combustion products is impractical, or heat at a temperature below 150°C cannot be put to use.

Measuring heating values

Higher calorific value is experimentally determined in a bomb calorimeter. Combustion in a container of a stoichiometric mixture of fuel and oxidiser (for example two moles of hydrogen and one mole of oxygen) is initiated by an ignition device and the reaction is allowed to complete. When hydrogen and oxygen react during combustion water vapour is produced. The starting vessel and its contents are then cooled to the original temperature and the higher calorific value is determined as being the heat released between the identical initial and final temperatures.

When the LCV is determined, cooling is stopped at 150°C and the heat of reaction is only partially recovered. The limit of 150°C is an arbitrary choice.

The heat of combustion is conventionally measured with a bomb calorimeter (ISO 1716, ASTM D4809).

Most standard natural-gas appliances (for example water heaters, gas furnaces, gas ovens) operate with an excess of air, and the water vapour

does not condense but remains as water vapour (steam) in the exhaust stream. This is also true for reciprocating internal combustion engines and gas turbines. In the United States the efficiency of appliances and heat engines is usually rated based on the HCV, whereas in European countries LCV is used. The LCV practice is probably based on the realisation that the heat of condensation is not a recoverable part of the fuel's energy, because it is not practicable to cool sulphur-bearing flue gas to below its dew point.

Engine and generator heat rates and efficiency

In the following sections the term heat rate (HR) is utilised in different scenarios.

Fuel engine

Fig. 4 shows the fuel data terms of mass flow (\dot{m}), the lower calorific value as (LCV), the output from the engine (mechanical power) as (P_m), the electrical power from the generator as (P_e), and the generator efficiency as η_G . Based on these definitions, the following relationships may be established, as shown in equations (1) to (5), see Fig. 4.a

Dual fuel engines

Based on the data in Fig. 5 the following relationships may be established, as shown in equations (6) to (11), see Fig. 5.a

The quantity of pilot fuel is typically 0.5% of MCR engine heat rate and is almost constant at all loads, i.e. the percentage of pilot fuel of the total heat rate is higher at lower loads.

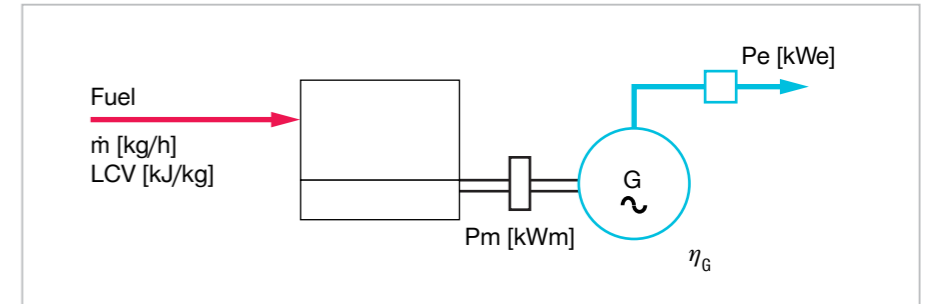

Fig. 4: Fuel engine with generator

$$HR, \text{ mech} = \frac{(\dot{m} \times LCV)}{P_m} \quad [\text{kJ/kWhm}] \quad (1)$$

$$HR, \text{ elec} = \frac{(\dot{m} \times LCV)}{P_e} \quad [\text{kJ/kWhe}] \quad (2)$$

$$HR, \text{ mech} = HR, \text{ elec} \times \eta_G \quad (3)$$

$$\text{Efficiency, mech} = \frac{3600}{(HR, \text{ mech})} \times 100 [\%] \quad (4)$$

$$\text{Efficiency, elec} = \frac{3600}{(HR, \text{ elec})} \times 100 [\%] \quad (5)$$

Fuel equations

Fig. 4.a: Equations

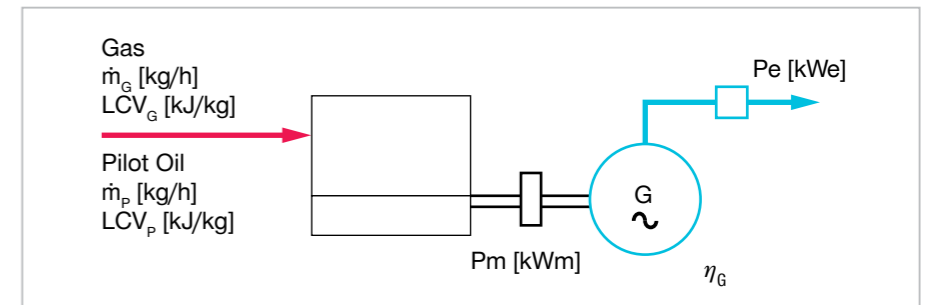

Fig. 5: Dual fuel engine with generator

$$HR, \text{ mech, gas} = \frac{(\dot{m}_g \times LCV_g)}{P_m} \quad [\text{kJ/kWhm}] \quad (6)$$

$$HR, \text{ mech, pilot} = \frac{(\dot{m}_p \times LCV_p)}{P_m} \quad [\text{kJ/kWhm}] \quad (7)$$

$$HR, \text{ elec, gas} = \frac{(\dot{m}_g \times LCV_g)}{P_e} \quad [\text{kJ/kWhe}] \quad (8)$$

$$HR, \text{ elec, pilot} = \frac{(\dot{m}_p \times LCV_p)}{P_e} \quad [\text{kJ/kWhe}] \quad (9)$$

$$\text{Efficiency, mech} = \frac{3600}{(HR, \text{ mech, gas} + HR, \text{ mech, pilot})} \times 100 [\%] \quad (10)$$

$$\text{Efficiency, elec} = \frac{3600}{(HR, \text{ elec, gas} + HR, \text{ elec, pilot})} \times 100 [\%] \quad (11)$$

Dual fuel, equations

Fig. 5.a: Equations

Engines with TCS and BCST

The turbo compound system (TCS) is an installation comprising a power turbine coupled to a generator utilising exhaust-gas heat for the additional production of electrical energy. A bottoming cycle steam turbine (BCST) is an installation utilising exhaust-gas heat for the additional production of electrical energy. Based on the data in Fig. 6 relationships may be established as shown in equations (12) and (13), see Fig. 6.a. The above methods can be readily adapted for dual-fuel engines.

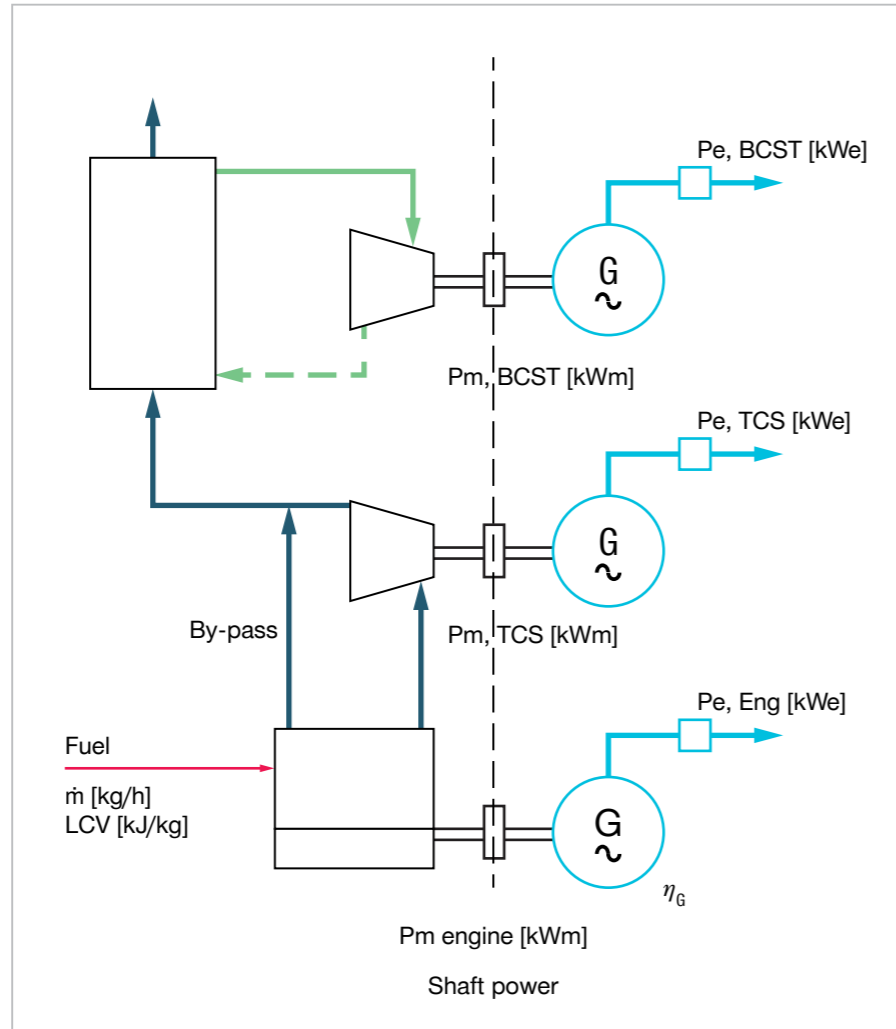

Fig. 6: Engines with TCS, HRSG, steam turbine and generator

$$HR, \text{ mech} = \frac{(\dot{m} \times LCV)}{(P_{m,Eng} + P_{m,TCS} + P_{m,BCST})} \text{ [kJ/kWhm]} \quad (12)$$

$$HR, \text{ elec} = \frac{(\dot{m} \times LCV)}{(P_{e,Eng} + P_{e,TCS} + P_{e,BCST})} \text{ [kJ/kWhe]} \quad (13)$$

Equations

Fig. 6.a: Equations

Power consumption in auxiliary systems

In addition to the foregoing explanation regarding the engine, generator and possible waste heat recovery in terms of BCST and TCS, the electrical power consumption of auxiliary systems must

be considered. A single-line electrical system is shown diagrammatically in Fig. 7 for a power plant equipped with a 10G90ME-S engine.

The transformer to the right in the single-line diagram shown in Fig. 7 is connected to the auxiliary busbar

supplying power for local use, such as pumps, fans, auxiliary blowers, heaters, etc. An auxiliary generating set is indicated in case the plant must be prepared for a black start. The nominal voltage of a busbar is 60 kV, and for this reason the operational voltage is estimated to 105%, i.e. 63 kV.

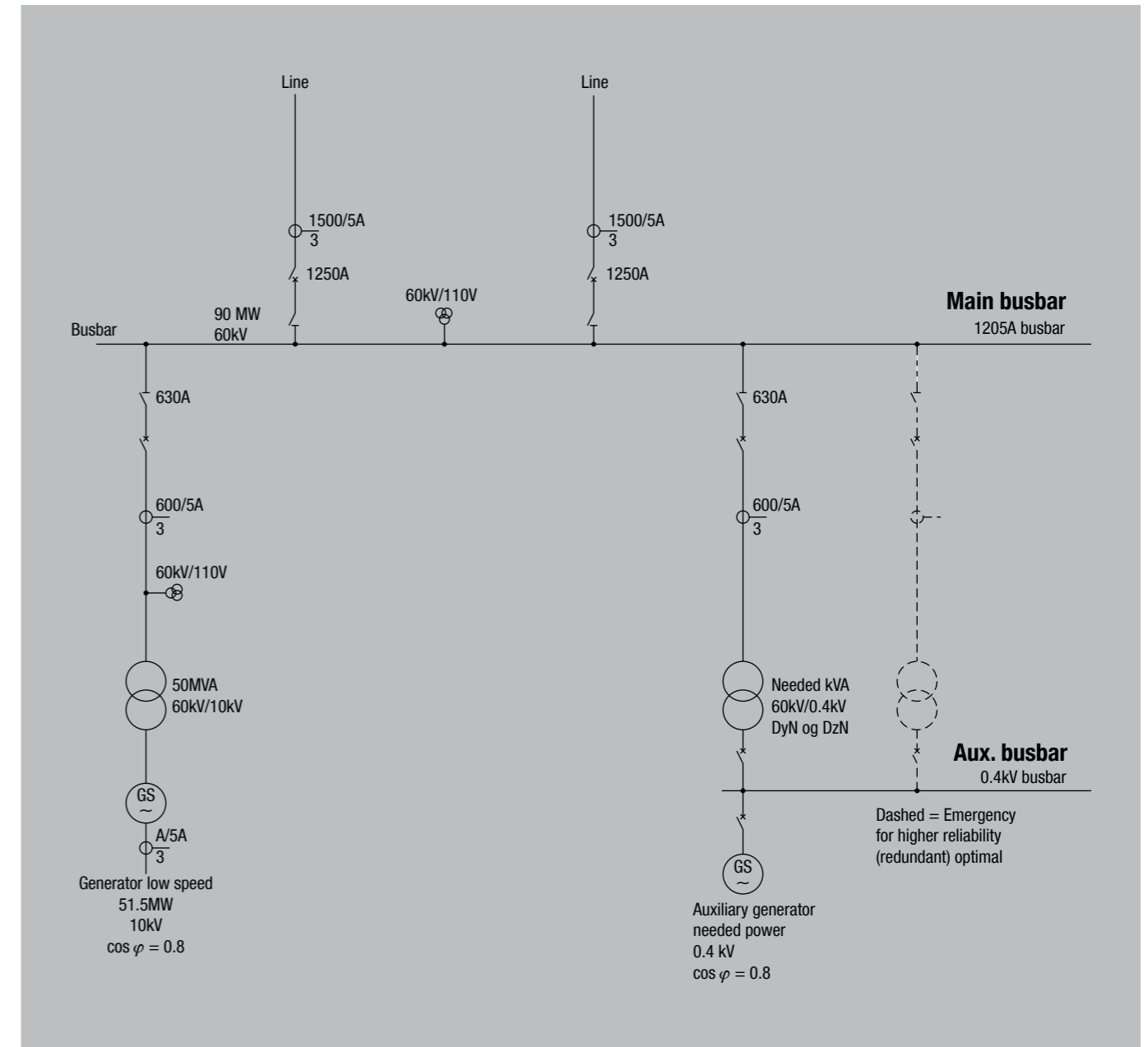

Fig. 7: Principle single-line diagram of power plant equipped with a 10G90ME-S engine.

The voltage level, however, varies from country to country. Fig. 8 provides explanations of symbols.

Based on Fig. 7, the following relationships may be established, as shown in equations (14) and (15).

Thermal efficiency

In thermodynamics, thermal efficiency (η_{th}) is a dimensionless performance measure of a device which uses thermal energy, such as a reciprocating internal combustion engine, a gas turbine, a steam turbine, a steam engine, a boiler or a furnace, for example. In other words, thermal efficiency indicates how well a process of energy conversion or transfer is accomplished.

In general, energy conversion efficiency is the ratio between the useful output of a device and the input, in energy terms, see equation (16). The net efficiency of a power plant may be expressed as shown in equation (17).

Power at power lines may be measured in kW. Input energy is the product of the lower specific heating energy [kJ/kg] of the fuel and the flow [kg/s] into the engine(s).

Let us assume that the output of a power plant is 195 MWe based upon an installation with engines and generators only, i.e. no BCST, no steam turbine nor TCS. Furthermore, assume the thermal input to be a mass flow of 9.42 kg/s.

If assuming a standard LCV fuel of 42.7 MJ/kg and the corresponding HCV to be 45.7 MJ/kg, then the thermal efficiencies would be as stated in equations (18) and (19), see Fig. 8.a

The above examples illustrate that although a constant quantity of fuel is going into the power plant and, at the same time, a constant quantity of electricity is leaving the power plant, the efficiency of the power plant differs due to the definition of the calorific value.

When comparing efficiency by means of different energy conversion systems, it is important to ensure that the same type of calorific value is used. By doing so, calculations will have a comparable baseline.

A power plant based upon MAN B&W engines may consist of multiple two-stroke engines, as shown diagrammatically in Fig. 9 for a 191.5 MWe installation with 10G90-ME-S.

If the total power is to be exported by means of one transmission line, one

solution may be to transform the voltage upwards and hence reduce the current and, consequently, the transmission-line resistance losses. The power loss in the transmission line is directly proportional to the resistance in the line and the square of the current.

Selection of the voltage for the main busbar depends upon the transformers available and the current for which the main busbar is designed. Generally, direct-coupled synchronous generators are designed for voltages of 10 to 15 kV, depending upon power size $P_{Loss} = IR^2$

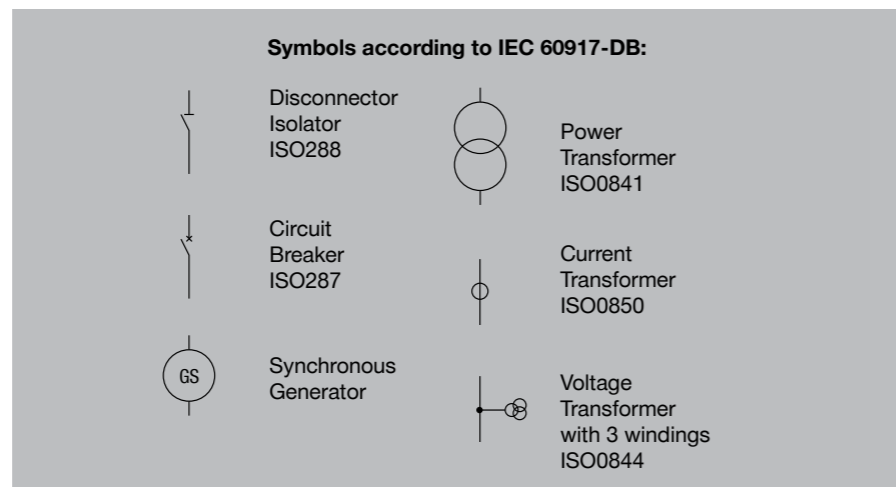

Fig. 8: Explanation of symbols used in Figs. 7 and 9

$$\begin{aligned} \text{Power at Main Busbar} &= P_{Gen} \times \eta_{Transformer} \text{ [kWe]} & (14) \\ \text{Power at power lines} &= P_{Busbar} - P_{Plant\ consumption} \text{ [kWe]} & (15) \\ \eta_{th} &= \frac{\text{output}}{\text{input}} & (16) \\ \text{Plant net efficiency} &= \frac{\text{(Electrical output at transmission lines)}}{\text{(Fuel in)}} \times 100 \text{ [%]} & (17) \\ \text{Examples: } \eta_{th\ LCV} &= \frac{195}{9.42 \times 42.7} \times 100 = 48.3\% & (18) \\ \eta_{th\ HCV} &= \frac{195}{9.42 \times 45.7} \times 100 = 45.2\% & (19) \end{aligned}$$

Equations

Fig. 8.a: Equations

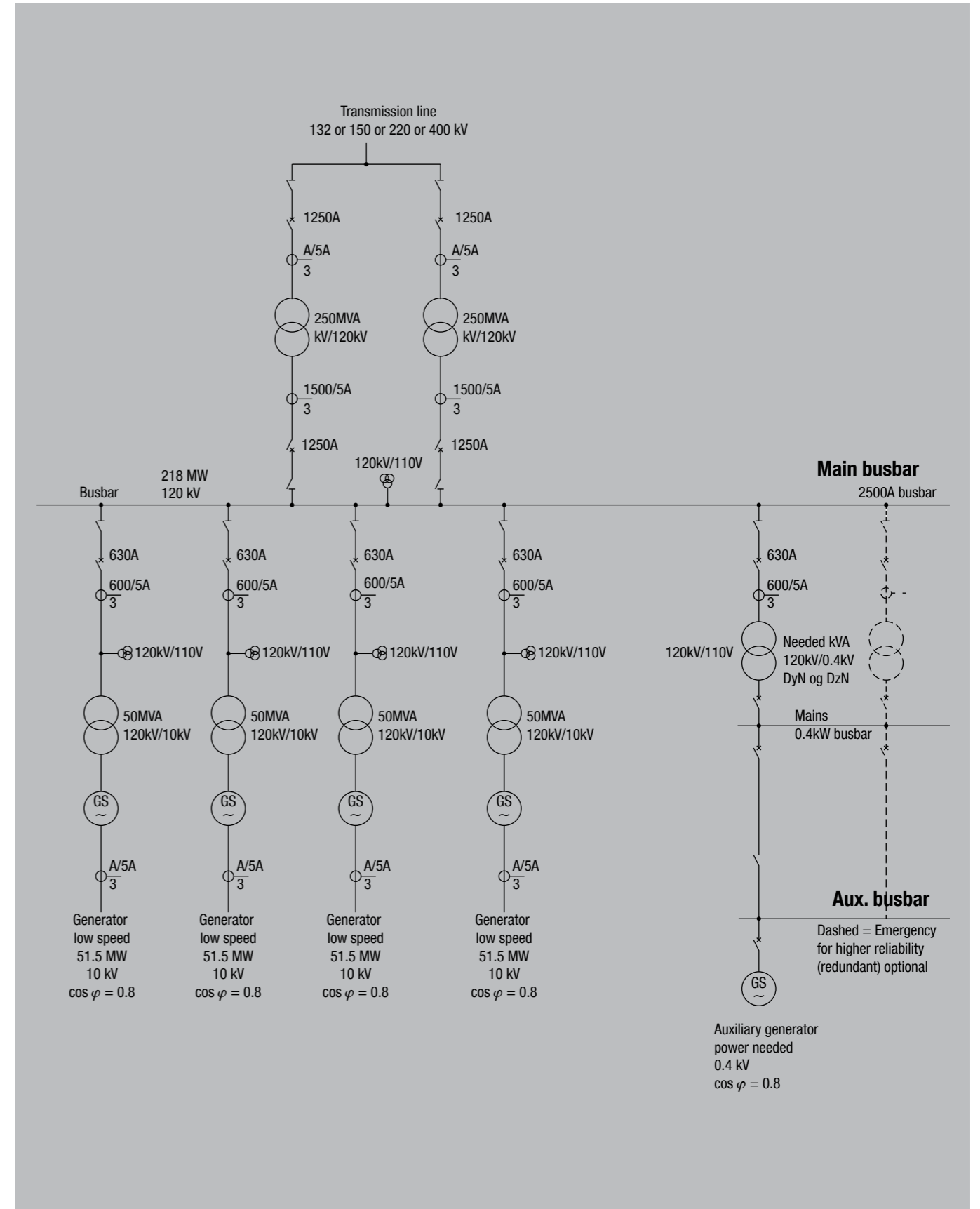

Fig. 9: 200 MWe power plant equipped with 4 x 10G90ME-S each rated to 51,500 kWm MCR at 83.3 rpm (50 Hz)

Due to the very high voltage at the main busbar, the auxiliary busbar has to be connected by means of two transformers because a 120/0.4 kV transformer would be of a special design.

Engine control

A marine engine coupled directly to a propeller is controlled by a governor which controls engine speed by means need for energy, being a function of the engine speed.

For a stationary engine coupled directly to a synchronous generator, the governor is extended with speed droop and pure kW control modes, to be utilised when the generator is connected to a grid.

The grid determines the frequency and the engine is forced to run at the speed required by the grid frequency. The governor performs speed control until the generator is connected to the grid, and once the generator is connected to the grid the governor performs load control. The governor mode selection and set points for the speed or load are determined by a power-plant control system.

Installation planning

Marine engines operate in an environment at sea level and at modest temperatures. The average load factor is lower when compared to its stationary counterpart.

Each stationary engine is optimised for the site-specific environment. The application of TCS or HRSG units in connection with a steam turbine enhances the electrical output.

The electrical efficiency of multiple transformers and auxiliary equipment has an impact on the net total efficiency of the power plant, hence CAPEX and OPEX should be evaluated in relation to overall plant efficiency. Generally speaking transformer efficiency is a function of initial cost.

High efficiency of the prime mover impacts directly on the overall efficiency of the whole plant. It is recommended that the efficiency of the prime mover should be studied when selecting/designing the power plant, together with examining any demanding ambient conditions.

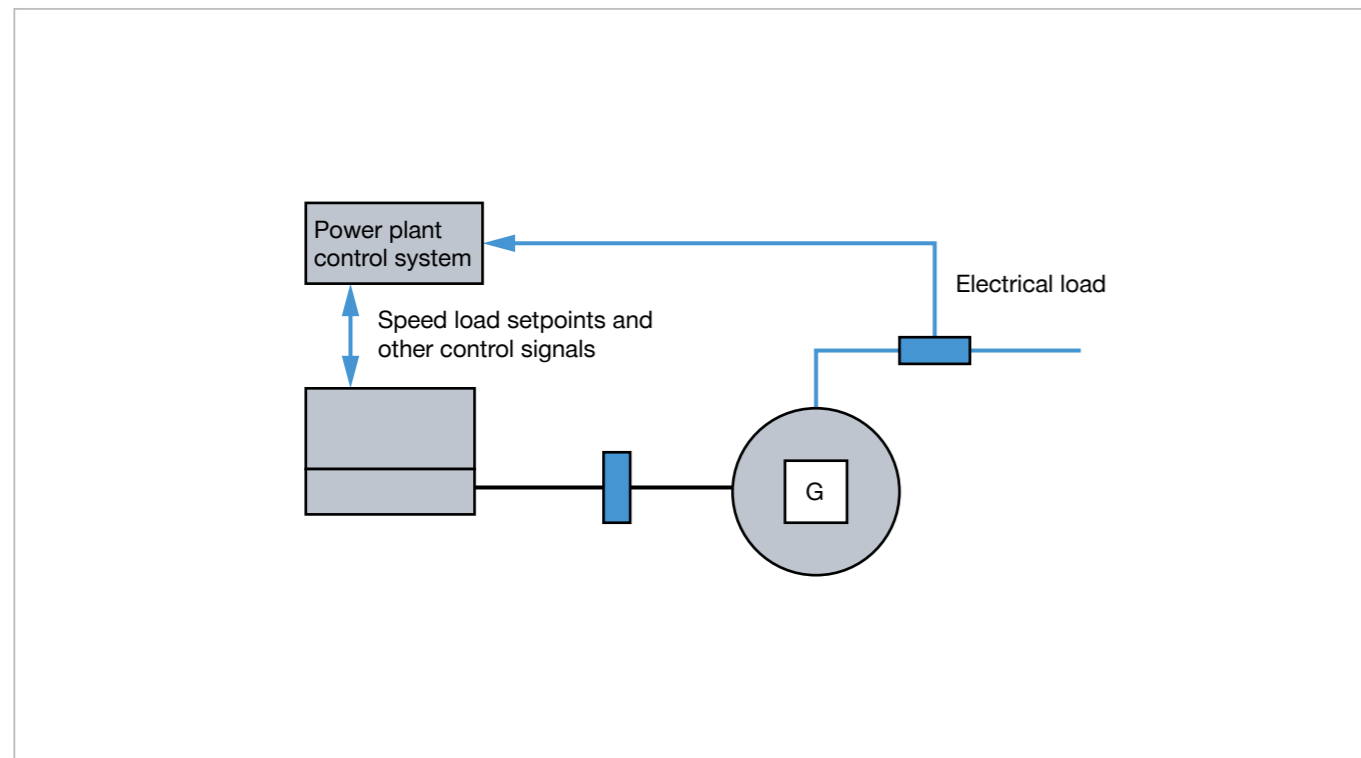

Figure 10: Engine-Generator control

References Abbreviations

References

- [1] EPA: Methods for Calculating Efficiency, <https://www.epa.gov/cph/methods-calculating-efficiency>
- [2] Efficiency of MAN B&W two-stroke engines, 5510-0200-00ppr Jan 2017

Abbreviations

- LCV – Lower Calorific Value [kJ/kg]
 HCV – Higher Calorific Value [kJ/kg]
 LPG – Liquefied Petroleum Gas
 DME – DiMethyl Ether
 HFO – Heavy Fuel Oil
 TCS – Turbo Compound System
 BCST – Bottoming Cycle Steam Turbine
 HRSG – Heat Recovery Steam Generator
 MAN B&W – Engine brand name
 MCR – Maximum Continuous Rating
 HR – Heat Rate [kJ/kWh]
 P_m – Power mechanical [kW]
 P_e – Power electrical [kW]
 ṁ – Mass flow [kg/h]
 η_G – Generator efficiency [%]
 ṁ_G – Mass flow of gas [kg/h]
 ṁ_P – Mass flow of pilot oil [kg/h]
 P_{e, BCST} – Power electrical from BCST [kW]
 P_{e, TCS} – Power electrical from TCS [kW]
 P_{e, Eng} – Power electrical from the engine delivered by the generator [kW]
 η_{th, LCV} – Thermal efficiency based on LCV [%]
 η_{th, HCV} – Thermal efficiency based on HCV [%]
 ISO – International Organization for Standardization
 ASTM – American Society for Testing and Materials
 FC – Fuel Consumption [g/kWh]

MAN Energy Solutions

2450 Copenhagen SV, Denmark

P +45 33 85 11 00

F +45 33 85 10 30

info-cph@man-es.com

www.man-es.com

All data provided in this document is non-binding. This data serves informational purposes only and is not guaranteed in any way. Depending on the subsequent specific individual projects, the relevant data may be subject to changes and will be assessed and determined individually for each project. This will depend on the particular characteristics of each individual project, especially specific site and operational conditions.

Copyright © MAN Energy Solutions.
5510-0200-02ppr Feb 2019 Printed in Denmark,
PrinfoTrekroner