

MAN

L32/44CR

Propulsion

The MAN 32/44CR engine represents the newest technologies in the area of medium speed marine diesel engines. By using electronic injection, high efficiency turbochargers, electronic hardware, and variable valve timing the MAN 32/44CR is a synthesis of the most advanced large engine technologies available.

Benefits at a glance

- High efficiency
- High specific power output
- Low emissions
- Low operating and life cycle costs
- Long maintenance intervals and service life
- High reliability

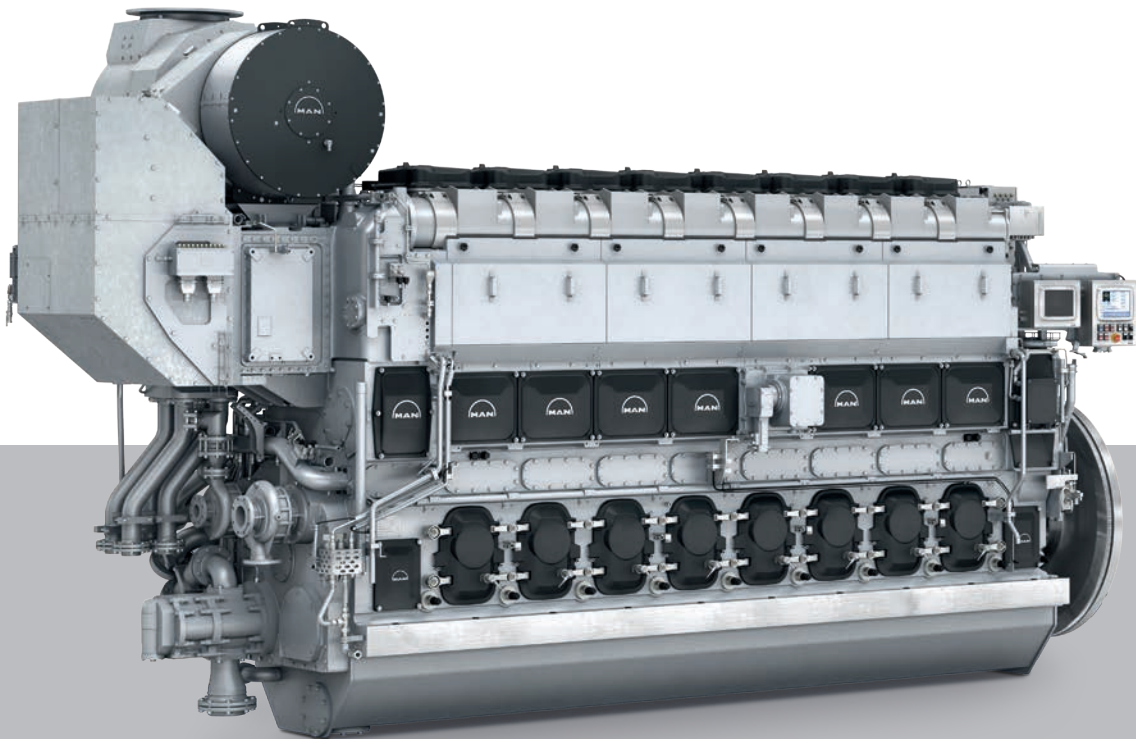

MAN L32/44CR

Propulsion

Dimensions

Cyl. No.		6	7	8	9	10
L	mm	6,312	6,924	7,454	7,984	8,603
L ₁	mm	5,265	5,877	6,407	6,937	7,556
W	mm	2,174	2,359	2,359	2,359	2,359
H	mm	4,163	4,369	4,369	4,369	4,369
Dry mass*	t	39.5	44.5	49.5	53.5	58.0

Output

Speed	rpm	750	720
mep	bar	27.1	28.3
MAN 6L32/44CR	kW	3,600	3,600
MAN 7L32/44CR**	kW	4,060	4,060
MAN 8L32/44CR	kW	4,800	4,800
MAN 9L32/44CR	kW	5,400	5,400
MAN 10L32/44CR	kW	6,000	6,000

Minimum centerline distance for twin engine installation: 2,500 mm

Speed of 720 rpm for generator drive/constant speed operation only

*Including built-on lube oil automatic filter, fuel oil filter and electronic equipment

**580 kW/cyl

Fixed pitch propeller: 550 kW/cyl, 750 rpm

Wet oil sump available upon request

Last updated July 2018

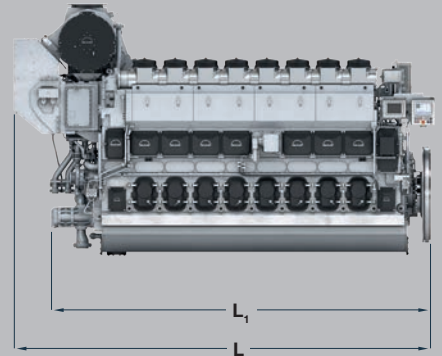
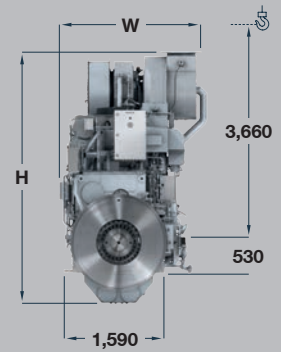

General

- Engine cycle: four-stroke
- No. of cylinders: 6, 7, 8, 9, 10
- Bore: 320 mm – Stroke: 440 mm
- Swept volume per cyl: 35.4 dm³

Fuel consumption at 85 % MCR*

- SFOC: 172 g/kWh
- SFOC: 173 g/kWh, 580 kW (7 cyl.)

Cylinder output (MCR)

- At 750/720 rpm: 600 kW
- At 750/720 rpm: 580 kW (7 cyl.)
- Power-to-weight ratio:
9.7 – 11.0 kg/kW

Compliance with emission regulations*

- IMO Tier II
- IMO Tier III (with MAN SCR)
- EPA Tier 2

Main features

Turbocharging system

- High efficiency constant pressure
MAN TCR series exhaust turbo-
charging system

Engine automation and control

- MAN in-house developed engine
attached safety and control
system MAN SaCoS_{one}

Fuel system

- Advanced electronic
common rail injection system

Lube oil system

- Attached lube oil automatic filter

Cooling system

- 2-string high and low temperature
cooling water systems

Starting system

- Pressurized air starter
(turbine type)

Engine mounting

- Resilient or rigid mounting

Optional equipment

- MAN ECOMAP concept – using
different IMO Tier II compliant
injection maps to improve fuel
economy
- Additional power take-off at engine
free end available

MCR = Maximum continuous rating
SCR = Selective catalytic reduction
SFOC = Specific fuel oil consumption
*According to IMO E2 test cycle

MAN Energy Solutions

86224 Augsburg, Germany
P + 49 821 322-0
F + 49 821 322-3382
info@man-es.com
www.man-es.com