

MAN TCA

Turbochargers

MAN TCA turbochargers are suitable for four-stroke and two-stroke gas, diesel and dual fuel engines in applications ranging from 3 MW up to 30 MW output per turbocharger.

Using fewer parts than any other generation of MAN axial turbochargers has reduced maintenance and service times, ensuring lower lifecycle costs.

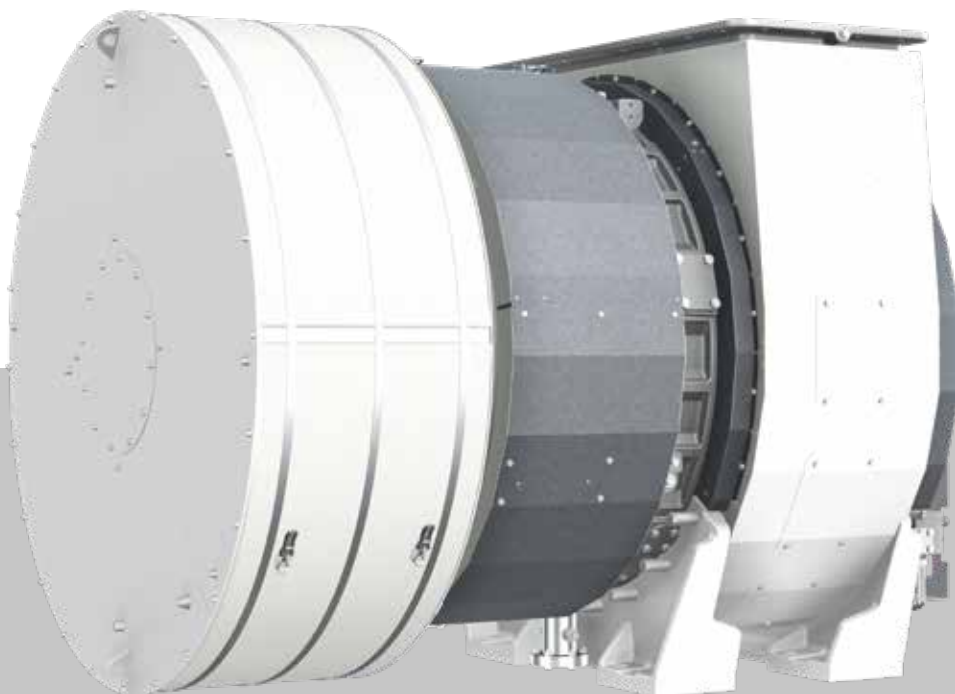

MAN TCA

Turbochargers

Dimensions

Type	L in mm	B in mm	H in mm	Weight in kg
MAN TCA33	1,558	802	1,021*	1,370
MAN TCA44	2,194**	1,054	1,614	1,950
MAN TCA55	2,167	1,206	1,825	3,200
MAN TCA66	2,360	1,433	2,094	5,300
MAN TCA77	2,782	1,694	2,371	8,330
MAN TCA88	3,316	2,012	2,734	14,000

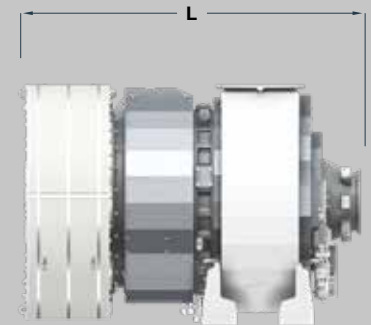
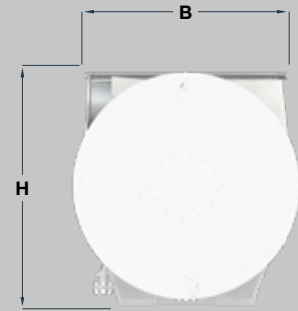

Type	Supercharged engine output		Max. permissible
	Two-stroke [kW]	Four-stroke [kW]	Speed [rpm]
MAN TCA33	-	5,400	27,800
MAN TCA44	7,400	7,900	22,700
MAN TCA55	10,200	10,400	20,000
MAN TCA66	14,600	14,800	16,900
MAN TCA77	20,700	21,000	14,200
MAN TCA88	32,400	30,000	12,000

Specific air consumption (Ie) 7.0 kg/kWh 6.5 kg/kWh

* Height without gravitation tank, all other heights including gravitation tank

** Gas admission casing 90°

All weights and dimensions are for guidance (project-specific requirements can lead to deviating values).
More information available upon request.

Last updated June 2023

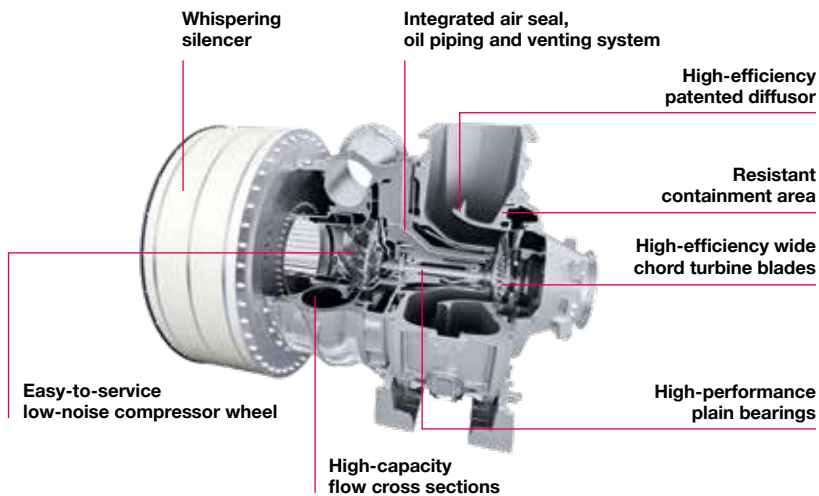

MAN TCA turbochargers are high-performance solutions characterized by ease of maintenance and long overhaul intervals. MAN TCA turbochargers are compliant with IMO Tier II and III and are suitable for all liquid fuels and gases.

Applications

- Marine propulsion
- Power generation
- Marine GenSets
- Offshore

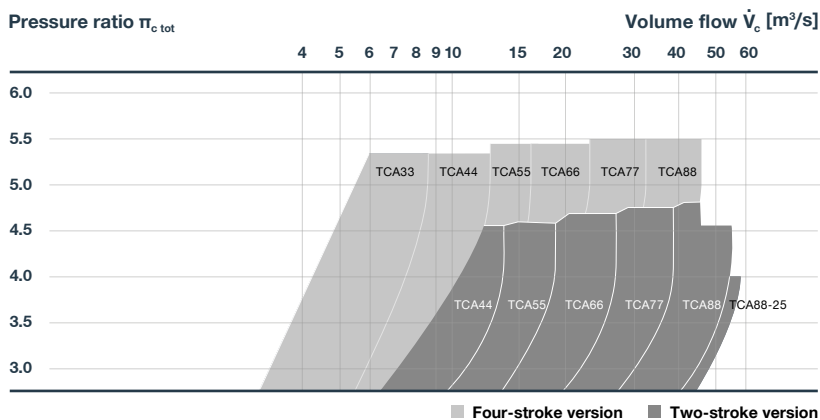

MAN Energy Solutions

86224 Augsburg, Germany

P + 49 821 322-0

F + 49 821 322-3382

turbochargers@man-es.com

www.turbocharger.man-es.com