

# Tier III upgrade

## MAN PrimeServ

**Retrofitting your vessel with a selective catalytic reduction (SCR) system from MAN Energy Solutions will reduce nitrogen oxides (NOx) emissions by up to 90%.**

Tier III compliance is ensured by the ability to operate the MAN SCR even at the lowest loads. The flexibility of the system even enables compliance with the special requirements specified by the NOx Fund, ESI, CSI, Green Award, and access to world heritage fjords, etc.

The MAN SCR is based on a component delivery concept that is directly connected to the engine control system, and which ensures a high operational safety with the minimum urea consumption.

The proven modular MAN SCR system design fits perfectly with all MAN four-stroke engines in service.

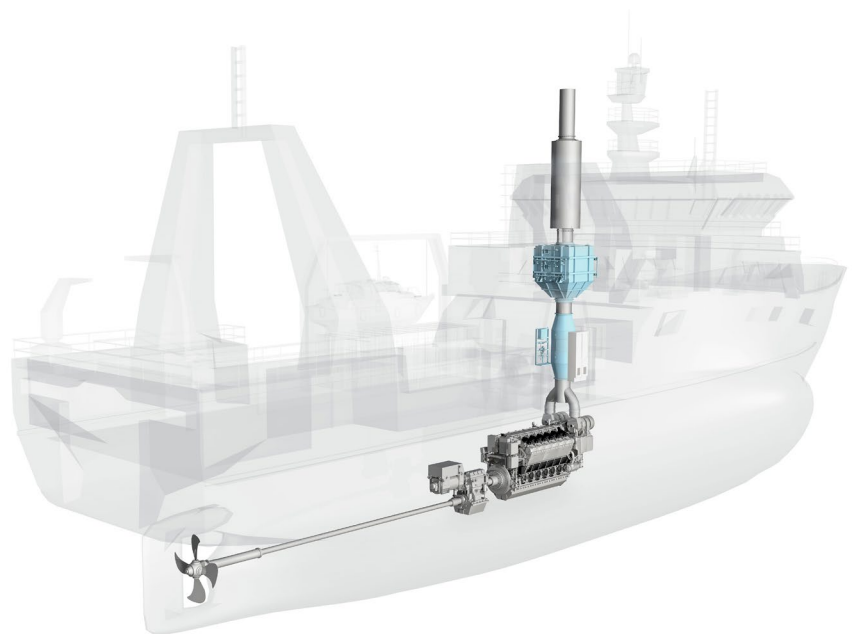

# Tier III upgrade

## MAN PrimeServ

### Key benefits

- Tier III compliance
- Tailor-made design and installation
- Efficient low-load operation with integration of waste gate system
- Automatic honeycomb regeneration process
- Reducing soot and smoke
- Urea efficient
- Optimized according to actual exhaust system back-pressure

### Scope of supply

- SCR components
- Planning & installation documentation
- Commissioning
- Customer documentation

### Applicability

Applicable for the MAN four-stroke engine portfolio



### Retrofit & Upgrades

PrimeServ Retrofit, Denmark  
RetrofitDK@man-es.com

### More information

Would you like to know more about the product, and how our upgrade solutions can improve your propulsion configuration? Then do not hesitate to contact your local MAN PrimeServ office to receive more information about the upgrade!

### MAN Energy Solutions

MAN PrimeServ Niels Juels Vej 15  
9900 Frederikshavn, Denmark  
P + 45 96 20 41 00  
RetrofitDK@man-es.com  
www.man-es.com/primeserv

All data provided in this document is non-binding. This data serves informational purposes only and is not guaranteed in any way. Depending on the subsequent specific individual projects, the relevant data may be subject to changes and will be assessed and determined individually for each project. This will depend on the particular characteristics of each individual project, especially specific site and operational conditions.

Copyright © MAN Energy Solutions. 3010-0464-00 March 2023