

CJC[®] Lube Oil Filter installation and operation guide

MAN PrimeServ

Apply to CJC[®] 27/- and 427/- single housing
series filter up to 2500 l/h

Contents

1. Introduction	2
2. Installation	2
2.1 CJC [®] Filter unit located adjacent to engine L.O. tank	2
2.2 CJC [®] Filter supply pump located adjacent to engine L.O. Tank	2
2.3 Piping length and dimensioning guide	3
3. Cleaning guide	3
3.1 Cleaning of the oil tank	3
3.2 Treatment of pipes and additional installations	3
4. Commissioning and Operation	4
4.1 CJC [®] Filter insert	4
4.2 Designed for continuous off-line lube oil cleaning	4
4.3 Taking the filter into service	5
4.4 Filter insert service life	5
4.5 Periodically partly lube oil change/sweetening	5



1. Introduction

As part of our Omnicare service, MAN PrimeServ provides oil filtration solutions and services from C.C.JENSEN. This document gives all necessary details for the installation and operation of the CJC® Engine Lube Oil Filter solution.

Note

- CJC® Engine Lube Oil Filter solutions are prepared for simple installation and operation, with no need for additional ancillary systems such as air, water or heating for the cleaning process
- CJC® Engine Lube Oil Filters with CJC® FlowDrive control systems are designed for continuous and unattended lube oil cleaning 24/7/360, independent of engine running or stand-by status
- To gain full benefit of the CJC® Lube Oil Filter and the CJC® FlowDrive solution, it is recommended to apply one CJC® Lube Oil Filter for each one engine lube oil system

2. Installation

2.1 CJC® Filter unit located adjacent to engine L.O. tank

CJC® Lube Oil Filter supplied with supply pump mounted on the filter housing.

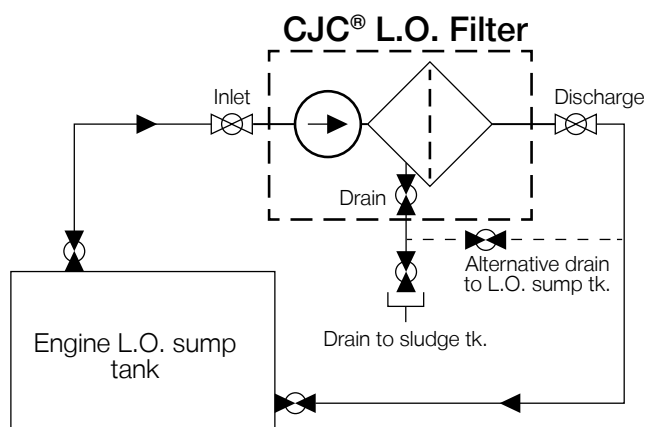

2.2 CJC® Filter supply pump located adjacent to engine L.O. tank

Optional

- Suction height > 1 m and/or suction piping > 15 m including elbow and valve equivalents
- CJC® Lube Oil Filter supplied with separate pump unit
- Apply CJC® installation kit

Note

Shielded power supply cable for supply pump electric motor.

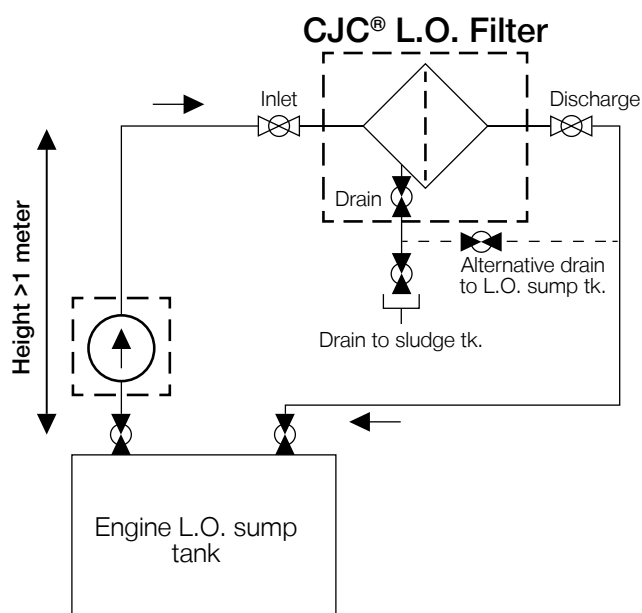

2.3 Piping length and dimensioning guide

The required minimum inner diameter of piping (total piping length = suction piping + return piping)

Note

Each 90-degree elbow or globe valve equals each one meter of piping length.



Nominal pump flow @ 60 Hz (L/h)	Total pipe length max 10 m	Total pipe length max 20 m	Total pipe length max 30 m	Total pipe length max 60 m
110	16 mm	16 mm	16 mm	19 mm
300	16 mm	18 mm	20 mm	24 mm
455	17 mm	20 mm	22 mm	27 mm
790	20 mm	23 mm	26 mm	31 mm
940	21 mm	24 mm	27 mm	32 mm
1,150	22 mm	25 mm	28 mm	33 mm
1,510	23 mm	27 mm	30 mm	36 mm
2,015	25 mm	29 mm	32 mm	39 mm
2,305	26 mm	33 mm	33 mm	40 mm

3. Cleaning guide

3.1 Cleaning of the oil tank

New or repaired components are often the carriers of contamination. Before final assembly, this built-in contamination must be removed from the blocks, pipes, oil tank, and any other components prepared for use in the system.

3.2 Treatment of pipes and additional installations

Hydraulic pipes should only be welded if absolutely necessary. If so, each welding point must be placed so that mechanical removal of any welding slag is possible.

All pipe dimensions larger than $\varnothing 25$ mm (externally) should be fitted with flanges if possible. The flanges and pipes must always follow the requirements of the class.

All cut surfaces must be ground, and the inner surface must be smooth. Any slag (and other impurities) must be removed mechanically. Clean all visible impurities. Scale on the inner surface must be treated with a de-scaling agent. If rust is found, the inner surface must be treated with de-rust agent. Use compressed air to remove small particles from the surface. Degrease all pipes using grease-dissolving liquid. Pipes that have been treated with acid are to be neutralised or washed in a combination of cleaning/neutralising agents.

Cleaned areas must be protected with an anti-rust agent immediately after being cleaned, so as to provide protection until the system is filled up. The agent must be of a type that can be mixed with lubricating oil.

When a pipe is treated with an internal protection agent, open connections must be blanked off (remember to remove all temporary gaskets and plugs, before assembly).

4. Commissioning and operation

4.1 CJC® Filter insert

The filter is always supplied with filter inserts designed for the specific engine and fuel type.

Insert type and article number are labeled on the filter name plate.

Engine type	Fuel type	Insert type
4-stroke, medium and high speed	Distillate fuel	CJC® LO4D 27/27
4-stroke, medium and high speed	Residual fuel	CJC® LO4R 2x27/27
2-stroke, low speed	Distillate and residual fuel	CJC® LOX 2x27/27

4.2 Designed for continuous offline lube oil cleaning

The CJC® FlowDrive system monitor the lube oil temperature at filter inlet and adjust the pump flow accordingly, enabling the filter to be in continuous service, independent of engine running or in stand-by.

Note

Flow decrease/increase at temperature change is controlled by a default ramp function. It may take several minutes before full flow response can be observed.

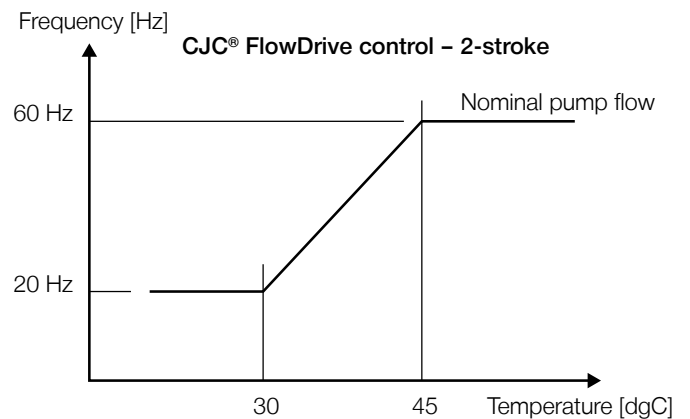
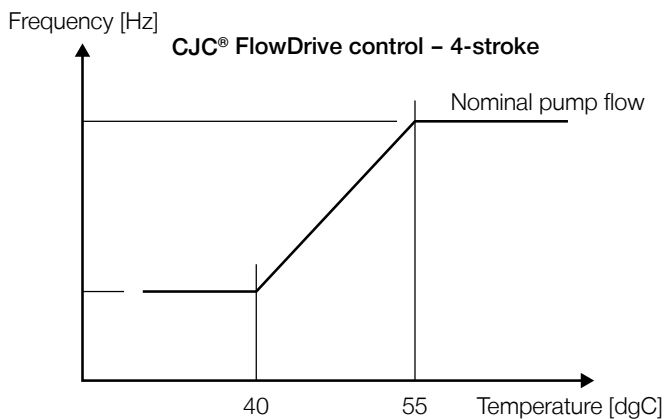

4.3 Taking the filter into service

The CJC® Engine Lube Oil Filter is equipped with a continuous air venting system and there is no need for manual venting.

Check filter pressure after the first start. If the filter is installed correctly the initial pressure should be between 0.1 and 0.3 bar.

4.4 Filter insert capacity and service life

Dimensioning of filter size and supply pump is based on engine type and fuel type applied. Expected filter insert life*:

- 4-stroke distillate fuel > 2,000 engine RHS
- 4-stroke residual fuel > 1,200 engine RHS
- 2-stroke HFO/MGO fuel > 2,000 engine RHS

*Valid for engines maintained and operated according to the manufacturer's recommendation.

Note

Filters retrofitted on existing engines will remove sludge accumulated in the lube oil system, and lower service life during the first 3-6 month may be expected.

4.5 Periodically partly lube oil change/ sweetening

The usage of CJC® Lube Oil Filter reduces uncontrolled lube oil waste and consequently the engine's lube oil consumption (SLOC) becomes very low.

- Low lube oil consumption (SLOC = 0.2 – 0.4 g/kWh) on HFO operated 4-stroke engines, may call for attention on alkalinity reserve/TBN depletion and on HFO contamination
- It is recommended to establish replenishment/sweetening procedures (15-20% of the oil volume) as a supplementary method for maintaining lube oil performance
- Above procedure will increase interval between complete oil change and cleaning of engine lube oil sump significantly



MAN Energy Solutions

MAN PrimeServ Omnicare Product Center
Rivium Quadrant 75
2909LC Capelle aan den IJssel
The Netherlands
primeserv-omnicare@man-es.com
www.man-es.com/omnicare

All data provided in this document is non-binding. This data serves informational purposes only and is not guaranteed in any way. Depending on the subsequent specific individual projects, the relevant data may be subject to changes and will be assessed and determined individually for each project. This will depend on the particular characteristics of each individual project, especially specific site and operational conditions.

Copyright©MAN Energy Solutions.
1510-0334-00ppr Jan 2024. Printed in Denmark.