



Smarter lube oil filtration

MAN PrimeServ



Proven oil filtration
solutions for
specific engine
types, from our
Omnicare service



Oil filtration systems from C.C.JENSEN gives you 97% energy (fuel) savings compared to a centrifugal separator

The global drive towards responsible shipping means our industry must find better ways to reduce its impact on the environment.

That's why, as part of our Omnicare service, we provide class-leading solutions that help to reduce fuel consumption, emissions, and waste, while improving OPEX.

Filtration units from C.C.JENSEN are designed to reduce energy consumption and prolong the life of your oil in a sustainable way. The filter elements are produced from environmentally sustainable, 100% natural cellulose fibers. The bonded discs' unique design creates a huge filtration area that ensures high efficiency.

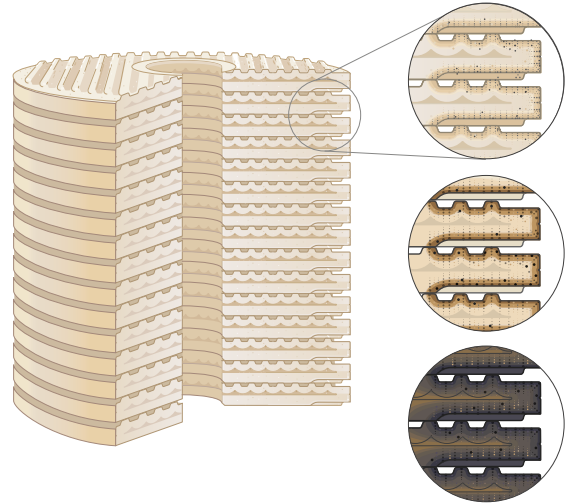

Fuel savings

Compared to a separator, a CJC® filter only requires 3% of the fuel. The majority of savings occur from heating the oil and spinning the motor on a centrifugal separator. For a centrifuge to be efficient, an oil temperature of 100-115°C must be maintained. Deviations from this range seriously impact the efficiency of the cleaning cycle.

97%
saving

Sludge reduction

With no oil loss during operation, sludge production is reduced to almost zero. Only a small amount is lost on element change. Substantial weight and space is saved on board by not having to transport the sludge back to port.

99%
sludge reduction

Specific lube oil consumption (SLOC)

Large savings in oil consumption drive down operating costs and further reduce environmental impact.

40-60%
saving on 4-stroke engines

10-20%
saving on 2-stroke engines

Simple installation and maintenance

C.C.JENSEN filtration units are easy to maintain with no special skills required. Their robust design with very few moving parts minimizes the risk of mechanical failure.

On retrofit applications, it is common to leave the centrifugal separator in place but switched off.

Common fault alarm output is available in case of pump stoppage, oil leaks, or related problems.

The cleaning period after the first installation might require an additional one or two sets of filter elements for the first year. This is dependent on the state of the oil on startup.

The offline system does not require a main system shut-down for maintenance or filter changes. Installation and maintenance are simple; no special tools or skills are required.

Expected filter insert life:

- 4-stroke distillate fuel > 2,000 engine running hours
- 4-stroke residual fuel > 1,200 engine running hours
- 2-stroke HFO/MGO fuel > 2,000 engine running hours

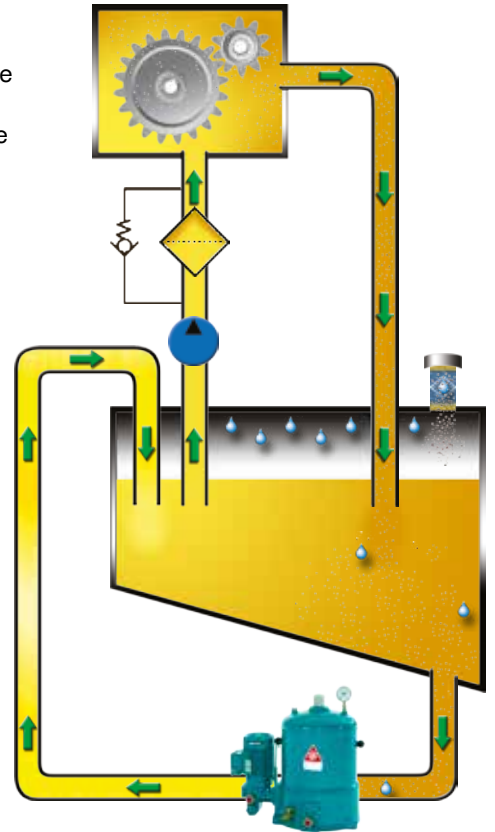

Installation procedure

1. Connect "T" supply and return lines onto existing centrifuge piping
2. Add power
3. Stop the centrifuge and start the C.C.JENSEN filter
4. Enjoy clean oil (no water or air required)

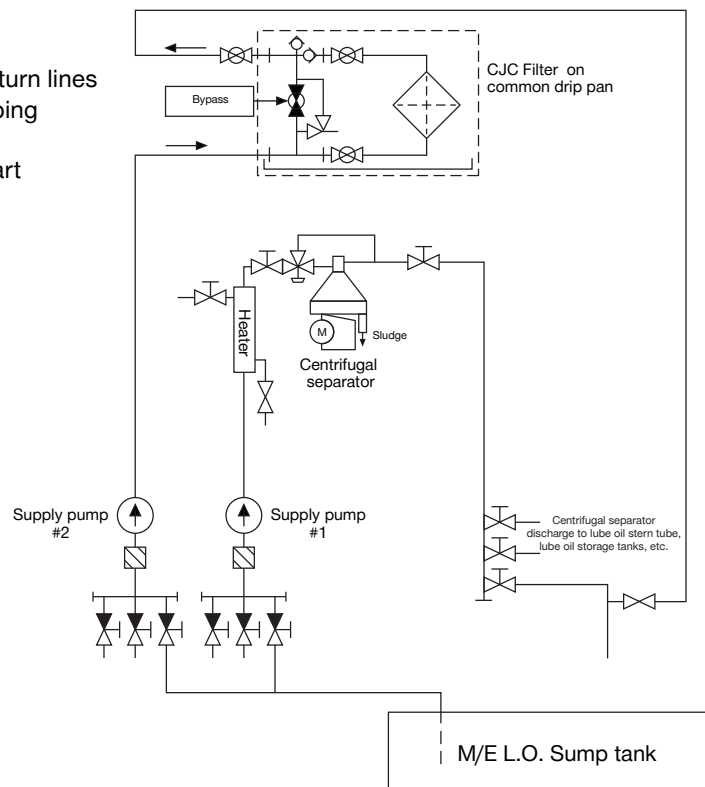



**Trusted by
the market
for over 70
years**

**Offline lube
oil filtration**

Three types of elements are designed for different types of engines



MDO/MGO
4-stroke



HFO
4-stroke



MDO/MGO/HFO
2-stroke

Filter element made from natural cellulose fibers



Variable speed drive maintains filtration efficiency as oil temperature drops

Optional standard drip pan

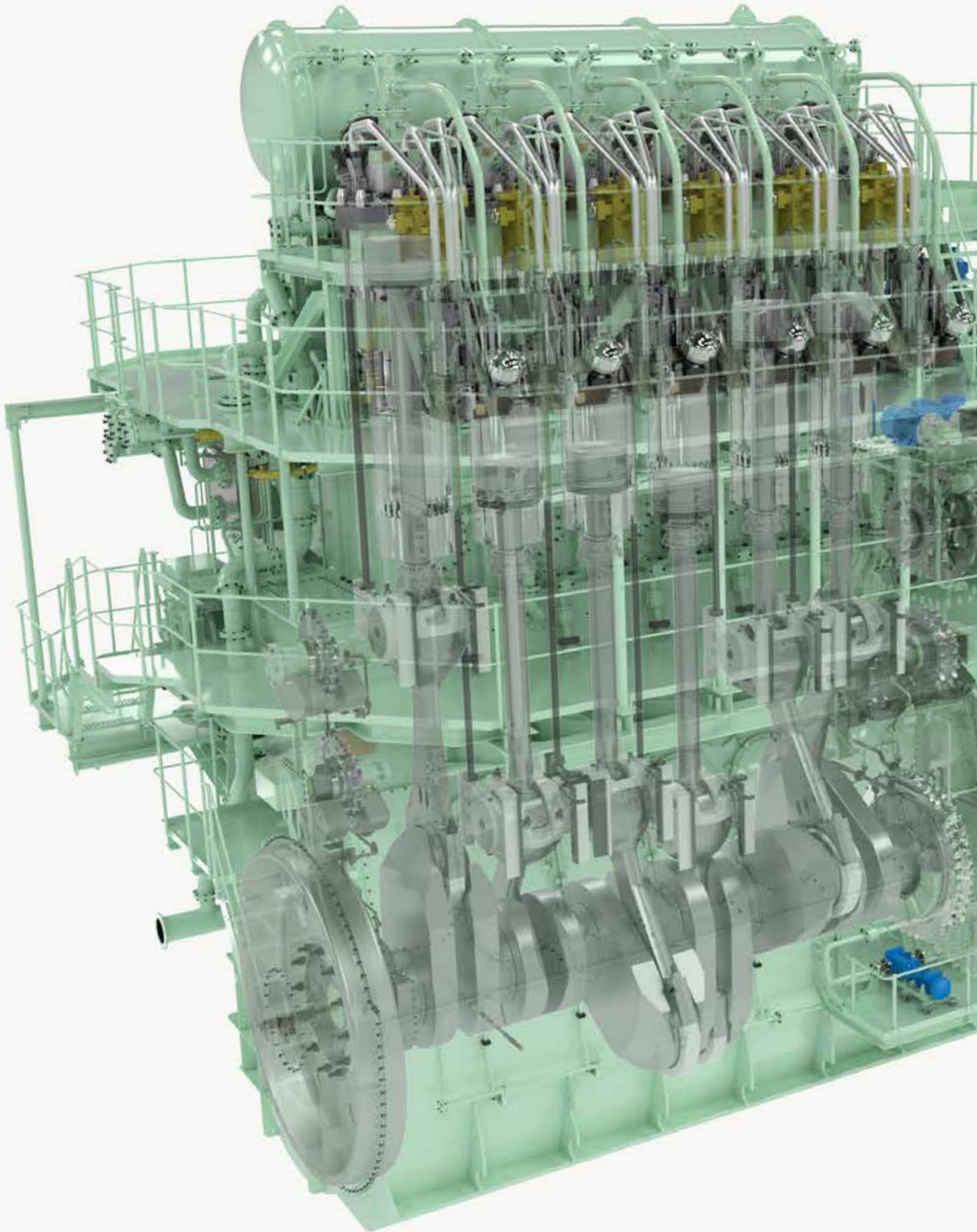



So... is my engine worth it?

Offline lube oil filtration makes sound financial sense, delivering fast ROI through significant fuel savings, lower oil consumption, and low sludge production.

Simple installation and low maintenance help to minimize running costs, while the solution's low energy consumption makes it possible to run the cleaning cycle almost 24/7/365 with 98% uptime. Filters from C.C.JENSEN extend oil and component life by 2-10 times with oil quality that matches or exceeds that of centrifugal separators.

Marine vessels generally have a high environmental footprint and there is growing pressure to reduce this. As these filtration units typically require only 3% of the fuel required by a separator, this translates into a substantial reduction in CO₂ emissions.

Our services include

- Support and advice for choosing the right filtration system
- Retrofit installations, new installations, spare parts, and replacement filter insertions with short delivery times
- Return on investment calculations to help evaluate your savings

6-18 months

typical return on investment

Want to know more?



MAN PrimeServ

Service with passion



MAN PrimeServ is the dedicated MAN Energy Solutions service brand. Via a network of over 100 service centers worldwide, MAN PrimeServ provides 24/7 service across the globe. Our range of services includes technical support, consulting and OEM spares, as well as maintenance, repair and comprehensive individualized service plans.



365

days a year

24

hours a day



MAN PrimeServ's aim is to provide

- Prompt delivery of high-demand OEM spare parts within 24 hours
- Fast, reliable and competent customer support
- Individually tailored O&M contracts
- Ongoing training and qualification of operators and maintenance staff
- Global service, 24 hours a day, 365 days a year
- Diagnosis and troubleshooting with our high-performance Online Service

Scan to download the MAN Energy Solutions Brochure Store app



App Store



Google Play

MAN Energy Solutions and legacy brands

MAN PrimeServ is our brand name for high-quality aftersales support for the entire MAN Energy Solutions product portfolio. Through refinements to our products and repair techniques, we ensure and enhance our technological leadership and technical expertise as an Original Equipment Manufacturer (OEM) for the brands united under MAN Energy Solutions.

Worldwide service

We offer retrofitting and upgrade services to bring engines and turbochargers already in service up to the very latest standards of performance and efficiency.

Using the latest digital technology, we enable you to maximize the performance and availability of your MAN equipment by accessing real-time data analysis, remote support and rapid solutions. We also offer an extensive range of training courses at MAN PrimeServ academies around the world.

Our service does not vary according to location. We know that a vessel may be built in Asia, operated in Europe for ten years and then move to Africa for the next ten years. That does not alter our focus on dedicated training, fast delivery of strategic spare parts, a comprehensive approach, or our tailored maintenance contracts.

For more information please visit
www.man-es.com/primeserv



100

Services centers
worldwide



MAN Energy Solutions

MAN PrimeServ Omnicare Product Center
Rivium Quadrant 75
2909LC Capelle aan den IJssel
The Netherlands
primeserv-omnicare@man-es.com
www.man-es.com/omnicare

All data provided in this document is non-binding. This data serves informational purposes only and is not guaranteed in any way. Depending on the subsequent specific individual projects, the relevant data may be subject to changes and will be assessed and determined individually for each project. This will depend on the particular characteristics of each individual project, especially specific site and operational conditions.

Copyright © MAN Energy Solutions.
1510-0335-00ppr Jan 2024.
Printed in Denmark.