

THM1304

Mechanical Drive

The THM 1304 heavy-duty gas turbine family offers a long life with a high level of reliability and availability. The modular design facilitates easy installation and maintenance features to realize an optimized cost-to-benefit ratio over the entire lifecycle. Onshore and offshore requirements for mechanical drive applications are perfectly met.

Benefits at a glance

- Modular design for easy and fast installation
- High reliability and availability
- Low emissions
- Fuel flexibility

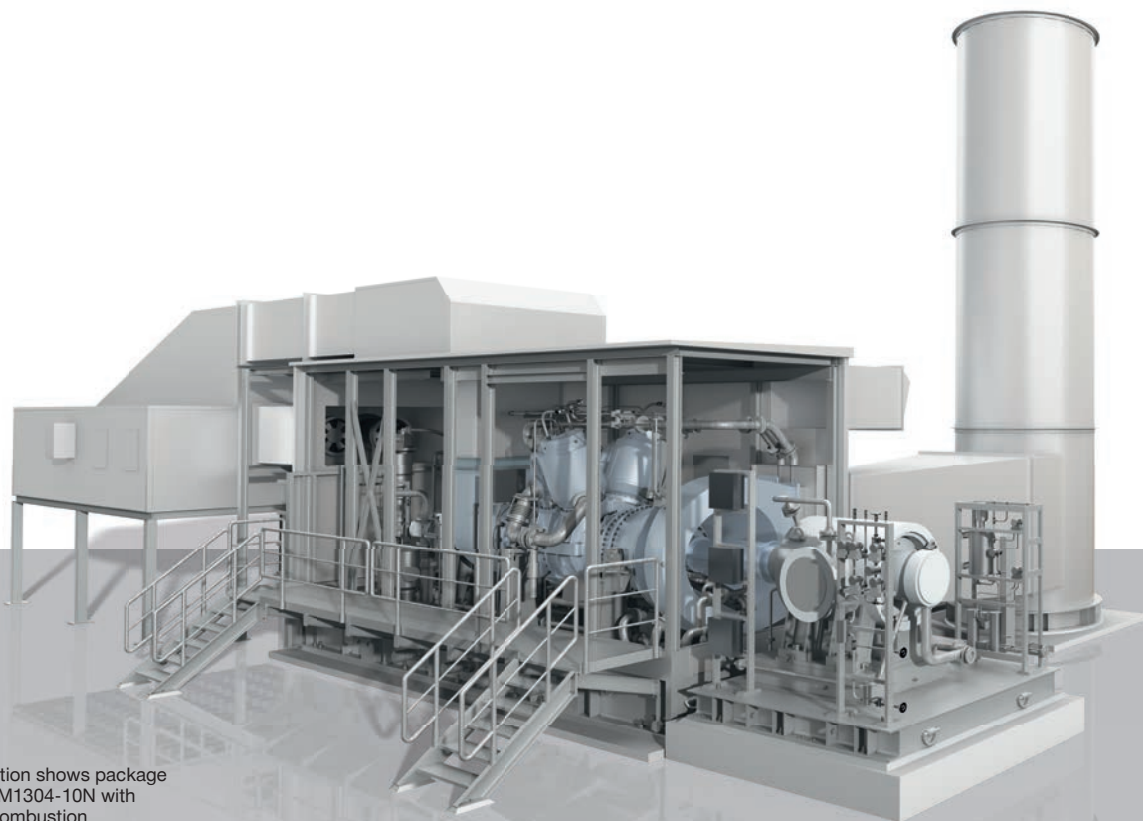

Illustration shows package for THM1304-10N with ACC combustion chambers

THM1304 Mechanical Drive

Technical data

Performance at ISO conditions*

		1304-10N**	1304-12N***
Power output	kW _{mech}	10,500	12,000
Heat rate	kJ/kWh _{mech}	11,840	11,610
Efficiency	% _{mech}	30.4	31.0
Exhaust gas flow	kg/s	46.5	48.1
Exhaust gas temperature	°C	490	525
Nominal power turbine speed	rpm	9,000	9,000
Power turbine speed range	%	43 - 105	43 - 105
NO _x emissions	mg/Nm ³	50	50
(ref. to 15% O ₂ , dry)	ppm	25	25
CO emissions	mg/Nm ³	20	10
(ref. to 15% O ₂ , dry)	ppm	16	8

*all data valid for sea level, 15 °C, no inlet and exhaust pressure losses, 60 % rel.humidity, natural gas. Power output will decrease with increase of site altitude (1.1 % per 100 m), inlet pressure loss (1.9 % per 1 kPa) and exhaust pressure loss (0.9 % per 1 kPa)

** ACC combustors,

*** DLN combustors

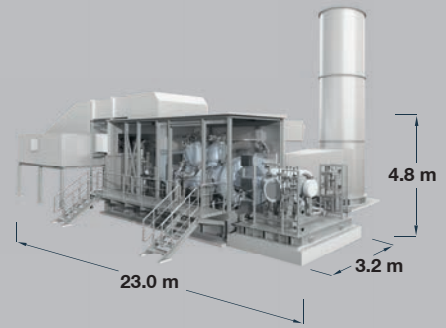

Layout based on THM1304-10N with ACC combustion system

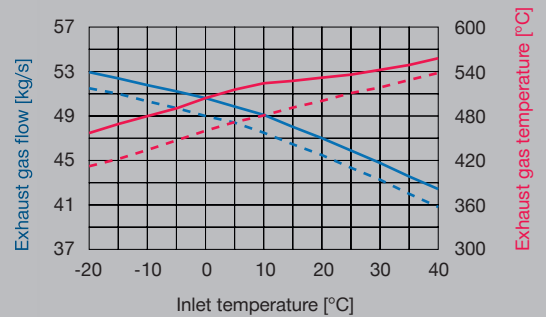
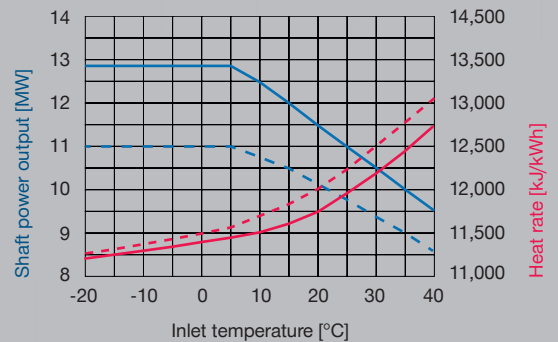
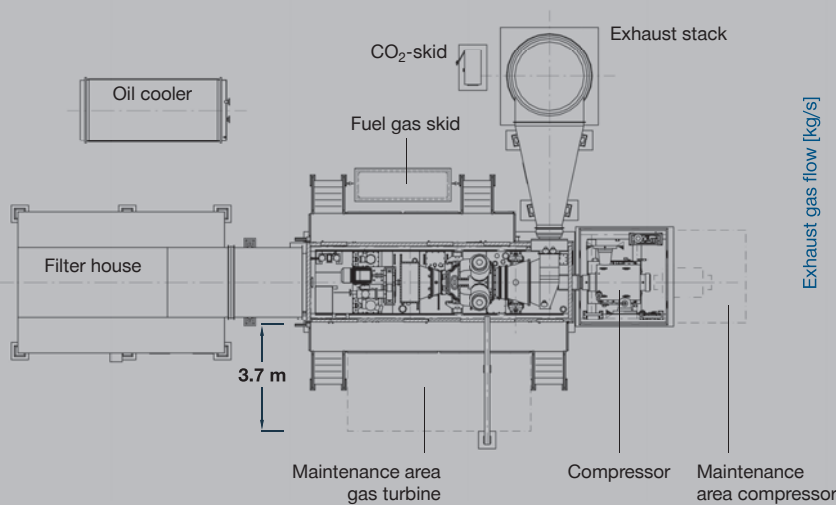

--- THM1304-10N
 — THM1304-12N

Typical applications

Twin shaft gas turbines have a variable speed drive shaft which is the best and most efficient way not only to control flow or discharge pressure, but also to start a mechanical drive train. Driven units are compressors and pumps for pressure increase and transport of gaseous and liquid media.

Typical application fields are midstream and upstream oil & gas production sites operating mainly in simple cycle mode.

Gas turbines of twin shaft design are also used for power generation at fixed speed. Selection criteria in such cases are e.g. the package design or driver communality in combination with mechanical drive units.

Gas turbine

- Heavy duty, twin shaft
- 11 stage air compressor
- 2 combustion chambers in V arrangement
- 2 stage high pressure turbine
- 2 stage power turbine

Combustion systems

- Low Emission combustion system
 - ACC¹⁾ combustors (THM1304-10N)
 - DLN combustors (THM1304-12N)
- Diffusion combustion system
 - Standard combustor
 - High fuel flexibility
 - Dual fuel compatible

Integrated auxiliary gear

- Parallel shaft gear type
- Drive for main lube oil pump
- Torque transmission of electric starter motor for gas turbine start-up

Driven unit

- Compressors for midstream applications (gas transportation & storage)
- Compressors for upstream applications (gas gathering, gas reinjection, etc.)
- Pumps

Gas turbine package

- Package for outdoor installation
- Noise emission
 - All equipment is designed for $L_{pA} = 85$ dB(A) measured in 1 m distance and 1.5 m height
 - $L_{pA} = 80^{2)}, 75^{2)}, 70^{2)}$ dB(A)
- Base frame
 - With integrated lube oil and fuel system
- Starting system
 - Variable frequency drive for gas turbine starter motor
- Integrated lube oil system
 - Main lube oil pump driven via auxiliary gear
 - Stand-by lube oil pump (AC-motor driven)
 - Emergency lube oil pump (DC motor driven)
 - Air to oil cooler (free standing)
 - Water cooler²⁾
 - Integrated lube oil tank
 - Lube oil tank heater
 - Lube oil filter
 - Control valves
 - Oil mist separator
- Fuel system
 - Fuel gas system
 - Double block and bleed valves
 - Control valves
 - Liquid²⁾ & dual fuel system²⁾ (standard combustor)
- Air inlet system
 - Table type filter house with depth loading cartridges
 - Filtration class:
 - Pre-filter: G4,
 - Fine-filter: F9 (E11²⁾)
 - Static filter²⁾ with anti-icing²⁾
 - Pulse type filter in table or down flow arrangement²⁾
- Exhaust system
 - Transition duct
 - Expansion joint
 - Free standing stack
- Enclosure
 - Gas turbine enclosure for outdoor installation
 - Fire detection and CO₂ fire-fighting system
 - Water-mist fire-fighting system²⁾
 - Gas leakage detection
 - Maintenance cranes
- Turbine compressor cleaning system
 - Offline and online washing
 - Mobile wash trolley²⁾

Controls

- For installation in air conditioned control room (to be provided by others)
- Gas turbine control system
 - Gas turbine control & protection
 - Unit sequencing
 - Human machine interface (HMI)
 - Alarm management
- Compressor control (if applicable)
 - Anti-surge controller
 - Performance controller
 - Load sharing²⁾
- Low voltage distribution system
 - AC power supply for all electrical consumers
- Turbine starting system
 - Variable frequency drive (VFD)
- Uninterrupted power supply system
 - Buffered with batteries
 - DC supply for emergency lube oil pump
 - AC supply for all electrical panels
- Data storage system
 - Long term data archive
 - Event logger
- Plant control system interface
 - Modbus TCP interface
 - Others optional

Documentation

- Engineering documents
- Installation manual
- Operating instructions
- Quality documentation

Factory acceptance test of turbine

- Core engine ASME PTC-22

Other tests²⁾

- According to API requirements

¹⁾ ACC = Advanced Can Combustor (Dry Low Emission (DLE) Technology)

²⁾ can be offered as option

MAN Energy Solutions

86224 Augsburg, Germany

P + 49 821 322-0

F + 49 821 322-3382

info@man-es.com

www.man-es.com

MAN Energy Solutions

Steinbrinkstr. 1

46145 Oberhausen, Germany

P + 49 208 692-01

F + 49 208 692-021

turbomachinery@man-es.com

www.man-es.com

All data provided in this document is non-binding. This data serves informational purposes only and is not guaranteed in any way. Depending on the subsequent specific individual projects, the relevant data may be subject to changes and will be assessed and determined individually for each project. This will depend on the particular characteristics of each individual project, especially specific site and operational conditions.

Copyright © MAN Energy Solutions. D02085031EN
Printed in Germany 10191.0