

Action code: **WHEN CONVENIENT**

**Laying up vessels
Preservation of engines
for cold laying-up**

SL09-510/SBJ
April 2009

Concerns

Owners and operators of MAN B&W two-stroke MC/MC-C, ME/ME-C and ME-B marine diesel engines and, furthermore, MAN Diesel four-stroke L16/24, L21/31, L27/38, L32/40, L23/30 (H) and L28/32 (H) marine GenSets

Dear Sirs

Lately, we have received requests from shipowners about instructions for laying up vessels for an unspecified period of time.

For this purpose, we have drawn up Recommendation No. 0743581-8, which is enclosed. The recommendation deals with the procedure for long term laying up of vessels with the main engine and auxiliary engines out of operation and in cold condition.

If you have any questions or inquiries regarding the recommendations, please contact our Operation Department at leo@mandiesel.com

Yours faithfully



Mikael C Jensen
Vice President, Engineering



Stig B Jakobsen
Senior Manager, Engineering

Encl.

Head office (& postal address)
MAN Diesel
Teglhølmegade 41
2450 Copenhagen SV
Denmark
Phone: +45 33 85 11 00
Fax: +45 33 85 10 30
mandiesel-cph@mandiesel.com
www.mandiesel.com

PrimeServ
Teglhølmegade 41
2450 Copenhagen SV
Denmark
Phone: +45 33 85 11 00
Fax: +45 33 85 10 49
PrimeServ-cph@mandiesel.com

Production
Teglhølmegade 35
2450 Copenhagen SV
Denmark
Phone: +45 33 85 11 00
Fax: +45 33 85 10 17
manufacturing-dk@mandiesel.com

Forwarding & Receiving
Teglhølmegade 35
2450 Copenhagen SV
Denmark
Phone: +45 33 85 11 00
Fax: +45 33 85 10 16

MAN Diesel
Branch of MAN Diesel SE, Germany
CVR No.: 31611792
Head office: Teglhølmegade 41
2450 Copenhagen SV, Denmark
German Reg.No.: HRB 22056
Amtsgericht Augsburg

**MAN B&W****Recommendation**

Info No.: 393 773		Laying-up of Vessels with Engines in Cold Condition	Ident No.: 0 74 35 81 - 8.
Scale:	Size: A4		Page No.: 1 (42)

Replacement for Ident. No.:

Date:	Des.	Chk.	A. C.	Revision change	Chg. Not.	Rev.
20090428	TOB	OLS				0
						1
						2
						3

This document is valid for existing engine types on order as of the date of this document:

MAN B&W Diesel: MC, MC-C, ME, ME-C, ME-B and

MAN Diesel four-stroke GenSets: L16/24, L21/31, L27/38, L32/40, L23/30(H), L28/32(H)

Contents

1. Scope and field of application
2. Reference
3. Prior to laying-up
4. Engine room and control room
5. Auxiliary supply systems
6. Preservation of main engine
7. Preservation of auxiliary engines
8. Preservation of turbochargers
9. Connection and operation of dehumidifier for the main engine
10. Connection of dehumidifier for the auxiliary engines.
11. Protection of electronic equipment
12. Equipment for preservation oil spraying
13. Maintenance of main engine preservation
14. Maintenance of auxiliary engine preservation
15. Preparation of turbocharger before recommencing service
16. Starting the main engine after the laying-up period
17. Starting the auxiliary engines after the laying-up period

**MAN B&W****Recommendation**

Info No.: 393 773		Laying-up of Vessels with Engines in Cold Condition	Ident No.: 0 74 35 81 - 8.			
Scale:	Size: A4		Page No.: 2 (42)			
Replacement for Ident. No.:						
Date:	Des.	Chk.	A. C.	Revision change	Chg. Not.	Rev.
20090428	TOB	OLS				0

1. Scope and field of application

This recommendation deals with the procedure for laying-up of vessels for an unspecified period, where qualified supervision is required for the engine room and the engines.

The recommendation should be used as guidance only. It is the shipowners responsibility to ensure proper maintenance and inspections during the laying-up period.

During the laying-up period, it is expected that the main engine and auxiliary engines are not operating and in cold condition as below:

The fuel oil system and lubricating oil system are filled and not operating.

Cooling water system is filled and not operating.

The atmosphere inside the engines must be controlled by dehumidifiers and kept below 50 % RH.

Sufficient electrical power should be available from external source for maintenance use and monthly operation of one main lubricating oil pump.

2. Reference

Reference is made to MAN Diesel Recommendation No 0743350-6.; Recommendation for laying-up of vessels with main engine in warm condition, i.e. cooling water system heated by a continuously operating auxiliary engine.

3. Prior to laying-up

We strongly recommend making a laying-up check list to ensure that laying-up maintenance diverting from "normal" port stay routines is performed correctly during the laying-up period and prior to the first engine start after the laying-up period.

3.1 Before stopping the main engine and auxiliary engines**Fuel system**

Operate the main and auxiliary engines on MDO (Marine Diesel Oil), by following the steps below:

Follow the change-over procedure for changing from Heavy Fuel Oil (HFO) to MDO

When the change-over has been completed, operate the main engine on MDO at full load for one hour or at minimum 75% load for two hours to flush out heavy fuel oil from the injection pumps, high pressure pipes and fuel injectors and to clean the exhaust system.

Operate the auxiliary engines on MDO for a minimum of one hour for each engine to flush out heavy fuel oil from the injection pumps, high pressure pipes and injectors before laying-up by following the change-over procedure for changing from HFO to MDO.

Copyright © MAN Diesel, branch of MAN Diesel SE, Germany, registered with the Danish Commerce and Companies Agency, under reg.no. CVR 31611792, (herein referred to as "MAN Diesel"). This document is the product and property of MAN Diesel and is protected by applicable copyright laws. This document and anything contained herein shall be treated as confidential by any party to whom it is submitted by MAN Diesel, and it is not to be disclosed to any third party without the specific, prior written permission of MAN Diesel.



Info No.: 393 773		Laying-up of Vessels with Engines in Cold Condition	Ident No.: 0 74 35 81 - 8.			
Scale:	Size: A4		Page No.: 3 (42)			
Replacement for Ident. No.:						
Date:	Des.	Chk.	A. C.	Revision change	Chg. Not.	Rev.
20090428	TOB	OLS				0

Turbocharger

Soft blast clean the turbine side.

Water wash the turbine side (if turbine shaft vibrations are observed during speed increase after the drying period: continue water washing).

If necessary: Soft blast clean the turbine side again.

Clean the compressor wheel by water washing.

Scavenge air cooler

If considered necessary, clean the scavenge air cooler air side in due time before laying-up as described in the instruction manual .

3.2 After stopping the main engine and auxiliary engines

Keep the main lubricating oil pumps and the jacket cooling water pump running for a minimum of 15 minutes after stopping the engine. This will prevent overheating of the piston top and combustion chamber.

As the fuel oil system for the main engine is filled with MDO, ensure that the valves for the fuel oil inlet pipe and fuel oil outlet pipe of the main engine are closed and the by-pass valve is open. Close also the ball shut-off valve for each fuel oil pump in the fuel oil pump inlet line. The auxiliary engines can now be changed back to HFO or continue operation on MDO until their final stop.

After stopping the auxiliary engines ensure that the valves for the fuel oil inlet pipe and fuel oil outlet pipe of each auxiliary engine are closed and the by-pass valve is open.

If the main engine and auxiliary engines have separate fuel oil systems, the procedure should be made for both fuel oil systems.

Secure the closed valves in locked position to prevent faulty operation during the laying-up period.

4. Engine room and control room

Keeping the recommended temperatures and humidity in the engine room and the control room will provide the best preservation of the mechanical and electronic equipment.

4.1 Engine room

Engine room temperature should be well above 0°C

If the engine room temperature is below 10°C this might have an influence of the capacity of the dehumidifiers for the engines and larger dehumidifiers may be required. See paragraph 9.

Keep the engine room well-ventilated.

**MAN B&W****Recommendation**

Info No.: 393 773		Laying-up of Vessels with Engines in Cold Condition	Ident No.: 0 74 35 81 - 8.
Scale:	Size: A4		Page No.: 4 (42)

Replacement for Ident. No.:

Date:	Des.	Chk.	A. C.	Revision change	Chg. Not.	Rev.
20090428	TOB	OLS				0

4.2 Control room

Control room temperature: 20-25°C
Humidity: 40-50% RH
Air condition: Permanently on

5. Auxiliary supply systems**5.1 Fuel oil system**

For treatment and preservation of the fuel oils, it is recommended to contact the oil company for advice and recommendations.

High temperature (especially in tropical waters) and high water content in the fuel oils, both HFO and MDO, will increase the risk of microbial growth. In order to minimise this risk, it is important to monitor the fuel oils and to keep the water content well below 0.3%. It can be recommended to consider the use of biocide in the fuel oil to avoid microbial growth.

The fuel oils might build up some acidic products during the oil aging process. These acidic products might cause corrosion. By adding, to the Day tank, a small percentage of antioxidation additive and anticorrosion additive suitable for this application, this could help to minimise this effect. After adding, circulate the fuel oil for one hour.

Once a month, it is recommended to analyse an HFO/MDO fuel oil sample at a laboratory for water content and microbial growth. The upper limit for the water content in fuel oils is 0.3%.

Once every six month, operate the fuel oil circulating pump for one hour.

If the main engine and auxiliary engines have separate fuel oil systems, the procedure should be made for both fuel oil systems.

5.2 Jacket cooling water system (high temperature, HT)

Do not drain the jacket cooling water system to avoid corrosion. Circulate the cooling water for one hour once a month.

It is expected that the jacket cooling water system is not exposed to temperatures below 0 °C.

Add rust inhibitor to the jacket cooling water system. After circulating the water, take a sample and analyse. Correct the condition if necessary. Follow the rust inhibitor manufacturers' recommendation.

In the event of the jacket cooling water being exposed to temperatures below 0 °C, Glycol must be added to obtain sufficient protection. Before starting the engine the jacket cooling water system has to be drained off and refilled with treated fresh water.

5.3 Central cooling water system (low temperature, LT)

Do not drain the central cooling water system to avoid corrosion. Circulate the cooling water for one hour once a month.

**MAN B&W****Recommendation**

Info No.: 393 773		Laying-up of Vessels with Engines in Cold Condition	Ident No.: 0 74 35 81 - 8.
Scale:	Size: A4		Page No.: 5 (42)

Replacement for Ident. No.:

Date:	Des.	Chk.	A. C.	Revision change	Chg. Not.	Rev.
20090428	TOB	OLS				0

It is expected that the central cooling water system is not exposed to temperatures below 0 °C.

Add rust inhibitor to the central cooling water system. After circulating the water, take a sample and analyse. Correct the condition if necessary. Follow the rust inhibitor manufacturers' recommendation.

In the event of the central cooling water being exposed to temperatures below 0 °C, Glycol must be added to obtain sufficient protection. Before starting the engine, the central cooling water system has to be drained off and refilled with treated fresh water.

5.4 Control air supply system

Drain the system for any condensate water. The valves for the control air and manoeuvring air supply to the engine must be closed.

6. Main engine preservation

Main engine preservation must be performed immediately after laying-up the vessel.

Preservation maintenance must be performed regularly during the entire laying-up period.

6.1 Preservation oil

All larger oil companies offer usable preservation oils. Some examples are listed below. Other preservation oils with corresponding qualities can be used.

It is of the outmost importance that the preservation oils can be dissolved in the main lubricating oil without damaging the properties of the lubricating oil. Please contact your main lubrication oil supplier for recommendations;

Esso Rust Ban 392

Tectyl 502-C, 930

Mobilarma 500

Dinitrol 40

BP Protective oil 20

Chevron EP Industrial oil 100 - 150

Shell Ensis Engine Oil SAE 30W

6.2 Main lubricating oil system

It is expected that sufficient electric power is available to operate the lubricating oil pump.

Start the main lubricating oil purifier and the purifier pre-heater 24 hours before turning of the crankshaft.

Start the main lubricating oil system one hour before the monthly turning of the crankshaft.



MAN B&W

Recommendation

Info No.: 393 773		Laying-up of Vessels with Engines in Cold Condition	Ident No.: 0 74 35 81 - 8.	
Scale:	Size: A4		Page No.: 6 (42)	

Replacement for Ident. No.:						
Date:	Des.	Chk.	A. C.	Revision change	Chg. Not.	Rev.
20090428	TOB	OLS				0

Keep the lubricating oil system running while turning the crankshaft.

Heating of the lubricating oil is not required during the laying-up period.

Once a month after stopping the purifier, analyse a lubricating oil sample for water content (MAN Diesel's upper limit is 0.2%). Analyse onboard and keep a record of the water content level.

As an alternative, it is recommended to use a laboratory to analyse the oil samples for water content.

6.3 Separate camshaft lubricating oil system and hydraulic power supply oil system

Once a month after stopping the purifier, analyse a lubricating oil sample for water content (MAN Diesel's upper limit is 0.2%). Analyse onboard and keep a record of the water content level.

As an alternative it is recommended to use a laboratory to analyse the oil samples for water content.

6.4 Cylinder Oil lubricators

Shut off the cylinder oil inlet supply to the lubricator(s).

6.5 Exhaust valves

During the lay-up period, the exhaust valves will open and remain open if the vessels control/working air system is shut down during the lay-up period. The wall surfaces of the exhaust valve air spring chamber needs protection against corrosion within the laying up period. The surfaces can be protected with system oil as described below. Below preservation procedure for MC and ME engines are separated.

The hydraulic oil for exhaust valve activation is for both engine types continuously refreshed via an orifice at the top of the exhaust valve. The replaced oil flows for the MC/-C version directly to the top of the spring air piston. For an ME/ME-C exhaust valve, the drain is led internally directly to the common drain line connection, i.e. the oil will not flow to the top of the air piston.

MC/MC-C/ME-B engines

After the final engine stop, keep the main lubrication oil pump running and perform the following:

One by one remove the exhaust valve air spring line and puncture the non-return valve (please note that an oil/air mixture will escape through the punctured non-return valve). Once the spring air chamber volume has escaped through the non-return valve, the exhaust valve opens, and the part of the air spring chamber above the air piston is filled with system oil supplied by the running lube oil pump.

When all exhaust valves have been opened and the spring air chamber filled with oil the air spring non-return valves should be removed. Through the hole for the removed non-return valve, spray preservation oil into the air spring space below the air spring piston. Fit the non-return valve here after.

The above procedure should only be performed once. At each monthly start of the main lube oil pump for engine turning, the air spring chamber will automatically be refilled.

Copyright © MAN Diesel, branch of MAN Diesel SE, Germany, registered with the Danish Commerce and Companies Agency, under reg.no. CVR 31611792, (herein referred to as "MAN Diesel"). This document is the product and property of MAN Diesel and is protected by applicable copyright laws. This document and anything contained herein shall be treated as confidential by any party to whom it is submitted by MAN Diesel, and it is not to be disclosed to any third party without the specific, prior written permission of MAN Diesel.

Info No.: 393 773		Laying-up of Vessels with Engines in Cold Condition		Ident No.: 0 74 35 81 - 8.	
Scale:	Size: A4			Page No.: 7 (42)	
Replacement for Ident. No.:					
Date:	Des.	Chk.	A. C.	Revision change	
20090428	TOB	OLS		Chg. Not.	Rev. 0

Figure 1

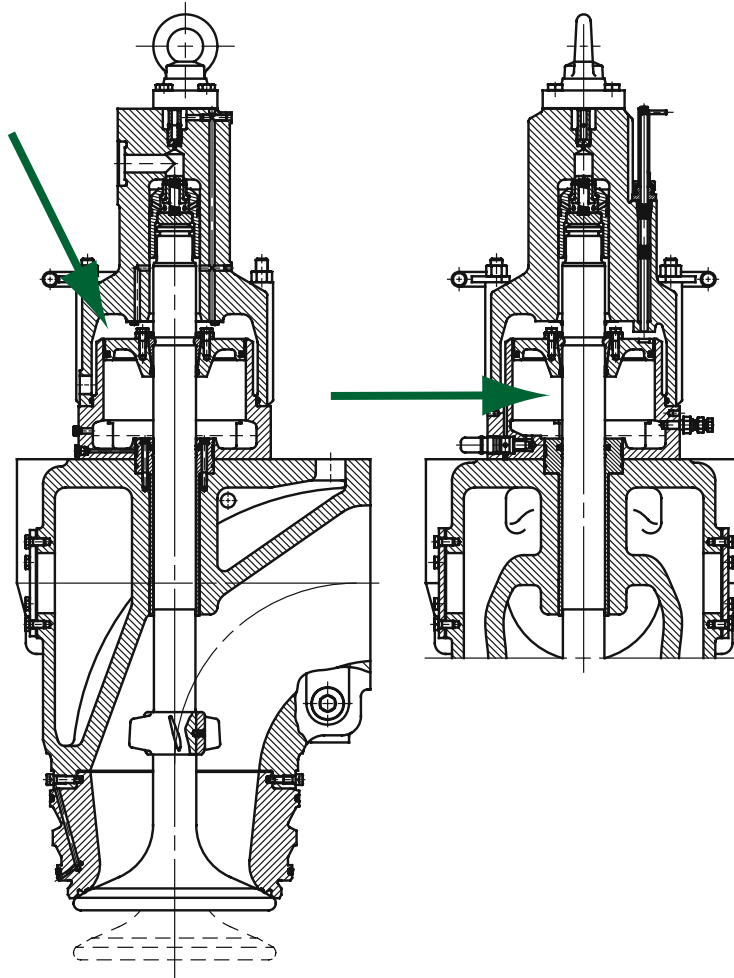

ME/ME-C engines

After the final engine stop and main lube oil pump stop, the exhaust valves are opened one by one by puncturing the non-return valve in the spring air inlet.

With open exhaust valves, the common drain line from each exhaust valve is removed. Oil can be filled into the space above the air piston in following way:

1. Connect a container/funnel to the drain hole via a flexible hose
2. Level the container/funnel above the air spring chamber and fill oil into the container
3. Fill continuously until no more oil runs into the air spring chamber
4. Lower the container/funnel below the air spring chamber in order to drain excessive oil prior to dismantling the flexible hose (thereby oil spill is eliminated)
5. Protect the chamber below the air piston as described for MC/-C exhaust valves



MAN B&W

Recommendation

Info No.: 393 773		Laying-up of Vessels with Engines in Cold Condition	Ident No.: 0 74 35 81 - 8.	
Scale:	Size: A4		Page No.: 8 (42)	

Replacement for Ident. No.:						
Date:	Des.	Chk.	A. C.	Revision change	Chg. Not.	Rev.
20090428	TOB	OLS				0

The above procedure shall only be performed once. After six months, it is recommended to refill the air spring chamber above the air piston as described in step 1-4. This is recommended as the space is not filled automatically during main lube oil pump operation.

Figure 2

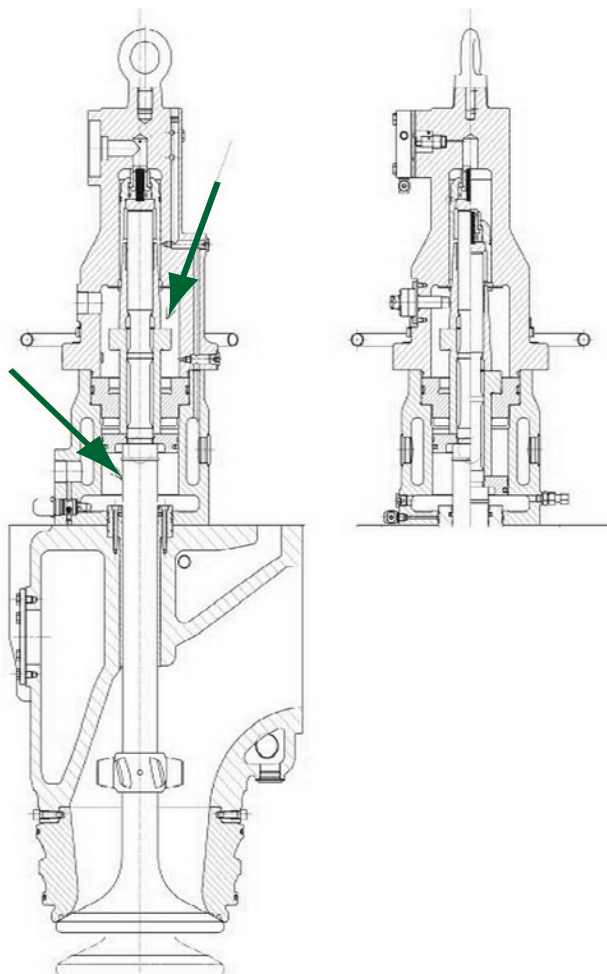

Copyright © MAN Diesel, branch of MAN Diesel SE, Germany, registered with the Danish Commerce and Companies Agency under reg. no. CVR 31611792, (herein referred to as "MAN Diesel").
This document is the product and property of MAN Diesel and is protected by applicable copyright laws. This document and anything contained herein shall be treated as confidential by any party to whom it is submitted by MAN Diesel, and it is not to be disclosed to any third party without the specific, prior written permission of MAN Diesel.

**MAN B&W****Recommendation**

Info No.: 393 773		Laying-up of Vessels with Engines in Cold Condition	Ident No.: 0 74 35 81 - 8.			
Scale:	Size: A4		Page No.: 9 (42)			
Replacement for Ident. No.:						
Date:	Des.	Chk.	A. C.	Revision change	Chg. Not.	Rev.
20090428	TOB	OLS				0

6.6 Fuel oil injection pumps

The fuel oil injection pumps must be isolated from the fuel oil supply line by closing the inlet valves for each pump. The MDO filled pump housings and pump injection components will be protected against corrosion.

MC/MC-C engines

Lift all the fuel roller guides clear from the cams by using the lifting tool in the roller guide housing.

For MC/MC-C engines with fuel oil injection pumps with variable injection timing VIT.

Protect the following spaces of the pump with preservation oil:

- A. Toothed bar for fuel regulation (index rod) and toothed bar for timing (VIT rod).

Loosen and remove the unions and pointers around the toothed rods from the fuel pump housing. Move the toothed bars in and out simultaneously while applying preservation oil to the bars.

- B. VIT regulating guide.

At the fuel pump housing base, a plug seals off access to the VIT regulating guide. Preservation oil can be applied to the regulating guide through the bore and sealed off by the mentioned plug.

- C. Space between pump barrel and top cover.

The drain (normally an outer drain line) from the space above the pump barrel should be removed. Through the open drain hole, preservation oil is sprayed into the mentioned space. Space between pump barrel and top cover.

- D. Dismantle the cover on the fuel pump base and spray preservation oil onto the sealing cap, lower end of the plunger and bottom flange of the fuel oil injection pump. Remount the cover.

- E. For preservation of the fuel and exhaust gear, dismantle the covers on the camshaft housing and spray preservation oil onto the springs and upper parts of the roller guides. Remount the covers.



MAN B&W

Recommendation

Info No.: 393 773	Laying-up of Vessels with Engines in Cold Condition	Ident No.: 0 74 35 81 - 8.
Scale: Size: A4		Page No.: 10 (42)

Replacement for Ident. No.:						
Date: 20090428	Des. TOB	Chk. OLS	A. C.	Revision change	Chg. Not.	Rev. 0

Figure 3

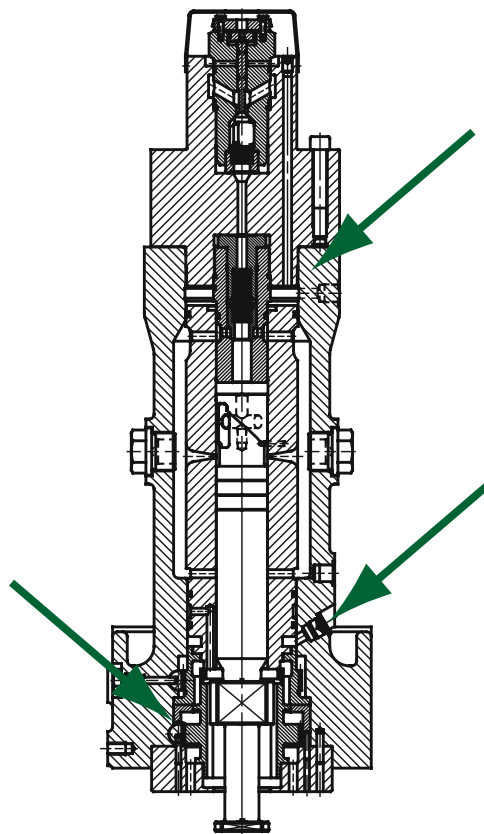
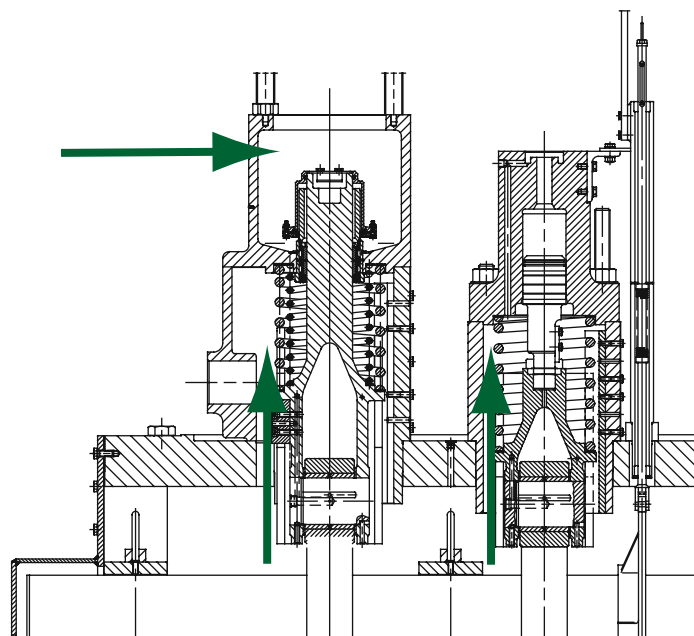

Figure 4 Fuel oil pump base , fuel and exhaust gear



Copyright © MAN Diesel, branch of MAN Diesel SE, Germany, registered with the Danish Commerce and Companies Agency under reg. no. CVR 31611792, (herein referred to as "MAN Diesel").
This document is the product and property of MAN Diesel and is protected by applicable copyright laws. This document and anything contained herein shall be treated as confidential by any party to whom it is submitted by MAN Diesel, and it is not to be disclosed to any third party without the specific, prior written permission of MAN Diesel.

Info No.: 393 773		Laying-up of Vessels with Engines in Cold Condition		Ident No.: 0 74 35 81 - 8.	
Scale:	Size: A4			Page No.: 11 (42)	
Replacement for Ident. No.:					
Date:	Des.	Chk.	A. C.	Revision change	
20090428	TOB	OLS			Chg. Not. Rev. 0

ME/ME-C/ME-B engines

Dismantle the sensor and spray preservation oil onto the tapered cap and lower part of the plunger and bottom surface of the barrel. Remount the sensor.

Figure 5

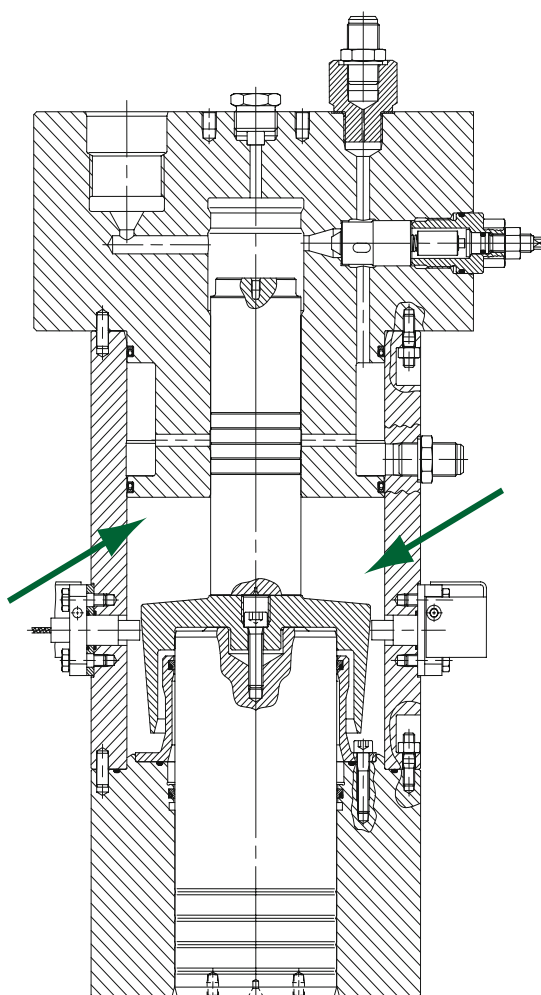

6.7 Fuel injection valves

We do not recommend overhauling and re-installing the fuel injectors one by one, for the following reasons:

Overhaul of fuel injectors without engine operation shortly after will increase the risk of trapping air in the system. Trapped air causes internal corrosion.

The fuel injectors can only be filled with oil after re-installation by opening the ball valve in the injection pump inlet line. If the fuel oil feed and circulation system is common for auxiliary engines and the main engine, HFO operation of the auxiliary engines will cause this fuel media to fill the just overhauled injectors of the main engine.

**MAN B&W****Recommendation**

Info No.: 393 773		Laying-up of Vessels with Engines in Cold Condition	Ident No.: 0 74 35 81 - 8.	
Scale:	Size: A4		Page No.: 12 (42)	

Replacement for Ident. No.:

Date:	Des.	Chk.	A. C.	Revision change	Chg. Not.	Rev.
20090428	TOB	OLS				0

Any leaks following injector overhaul or reinstallation may not be discovered during the laying-up period. The non-return valve located in the re-circulation line from each set of fuel injection valves is expected to make a tight closing, but in case of a leak, the closed ball shut-off valve in the fuel oil pump inlet line will prevent HFO to fill the fuel injectors during the laying-up period.

6.8 Mechanical governor

Follow the governor manufacturer's preservation instructions.

If no preservation instructions are available, the following instruction can be used, for guidance only:

Exchange the lubricating oil in the governor with new lubricating oil with same property specifications.

6.9 Reciprocating parts on the outside of the engine

Apply rust preservation oil onto all reciprocating parts on the outside of the engine (fuel index rods, VIT index rods and fuel-rack links, etc).

6.10 Outside machined surfaces

Apply Tectyl 502C onto all machined surfaces on the outside of the engine.

6.11 Crankcase relief valves

Follow the maintenance instruction from the manufacturer.

If no information is available related to the rust protection of the relief valve, it can be recommended to spray the flame arrester steel plates with preservation oil, Dinitrol 40 or similar.

Only cover the relief valve with proper protection in the event that painting, welding or grinding work is taking place nearby which can damage the relief valve.

6.12 Auxiliary blowers

Keep the electrical heating of the auxiliary blower motors operating continuously.

6.13 Cooling water system for air cooler

If the air cooler is cooled by sea water, we recommend closing the sea water inlet and outlet valves to the cooler and dismantling the pipes to the air cooler.

Connect hoses for fresh water flushing to the flanges of the cooler. When the cooler has been flushed sufficiently with fresh water, fill the cooler with fresh water with added rust inhibitor. Seal off the lower flange and fixate the end of the hose from the upper flange to a level one meter above the cooler. The opening of the hose must not be blocked so the water is able to expand without damaging the cooler.

Copyright © MAN Diesel, branch of MAN Diesel SE, Germany, registered with the Danish Commerce and Companies Agency, under reg. no. CVR 31611792, (herein referred to as "MAN Diesel"). This document is the product and property of MAN Diesel and is protected by applicable copyright laws. This document and anything contained herein shall be treated as confidential by any party to whom it is submitted by MAN Diesel, and it is not to be disclosed to any third party without the specific, prior written permission of MAN Diesel.

**MAN B&W****Recommendation**

Info No.: 393 773		Laying-up of Vessels with Engines in Cold Condition	Ident No.: 0 74 35 81 - 8.			
Scale:	Size: A4		Page No.: 13 (42)			
Replacement for Ident. No.:						
Date:	Des.	Chk.	A. C.	Revision change	Chg. Not.	Rev.
20090428	TOB	OLS				0

6.14 Piston rod stuffing boxes

Clean the scavenge air compartments underneath the liners and the air receiver itself shortly after laying-up. To neutralise any condensed acid in the oil trapped in the stuffing boxes, pour cylinder lubricating oil into each stuffing box while turning the crankshaft.

6.15 Components inside the engine

When carrying out preservation of the inside of the engine, keep the main lubricating oil pumps and camshaft oil pumps (if any) running until turning of the crankshaft has is completed.

Before carrying out the first preservation: Open up the scavenge air receiver and ventilate for minimum one hour. Clean the scavenge air chamber before starting preservation.

Preservation of the scavenge air chamber, including cylinder liners, pistons rods and piston crowns

Spray preservation oil onto the cylinder liner walls and piston crown top through the scavenge air ports when the piston is in bottom position.

Spray preservation oil onto the piston rings while turning the crankshaft. Repeat once for each cylinder. From start to finish of this procedure, the crankshaft must be turned exactly 3½ revolutions in all.

Stop lubricating oil pumps and camshaft oil pumps (if any). Let the lubricating oil in the crankcase drain off for minimum one hour before preservation of the crankcase.

Preservation inside the crankcase

Spray preservation oil onto the surfaces of the inside reciprocating parts, guide rails, chaindrive, chain wheels, etc., and close covers tight.

Preservation of camshaft housing

Spray preservation oil onto the camshaft including cams, rollers and roller guides, and remount covers.

6.16 Main engine exhaust pipe and crankcase venting pipe

Cover the main engine exhaust pipe in the top of the funnel during the laying-up period to protect against rain and dust.

Insert a blind flange between the crankcase and the crankcase venting pipe. This is necessary for the preparation of connecting the dehumidifier.

Should the top of the venting pipe be exposed to rain and dust, it is recommended to cover the venting pipe top.

6.17 Starting Air distributor

Dismantle the starting air distributor and apply lithium grease onto the inside parts for preservation. Assemble the starting air distributor according to the instruction manual.

Copyright © MAN Diesel, branch of MAN Diesel SE, Germany, registered with the Danish Commerce and Companies Agency, under reg.no. CVR 31611792, (herein referred to as "MAN Diesel"). This document is the product and property of MAN Diesel and is protected by applicable copyright laws. This document and anything contained herein shall be treated as confidential by any party to whom it is submitted by MAN Diesel, and it is not to be disclosed to any third party without the specific, prior written permission of MAN Diesel.



Info No.: 393 773		Laying-up of Vessels with Engines in Cold Condition	Ident No.: 0 74 35 81 - 8.			
Scale:	Size: A4		Page No.: 14 (42)			
Replacement for Ident. No.:						
Date:	Des.	Chk.	A. C.	Revision change	Chg. Not.	Rev.
20090428	TOB	OLS				0

6.18 Main starting air pipe

Keep the main starting air pipe dry: Remove the end cover of the pipe, insert dehumidifying vapour powder into the pipe and remount the end cover.

6.19 Exhaust gas receiver

After removing the turbocharger gas admission pipe, blank off the exhaust gas receiver outlet with a steel plate cover of 3-5 mm thickness. Adapt the cover to the flange of the compensator.

6.20 Turbocharger and exhaust pipe

Blank off the connection between the turbocharger outlet and the exhaust pipe with steel plate cover of 3-5 mm thickness. The purpose of the steel plate cover is to avoid dust and to protect the turbocharger from rain water if the exhaust system water traps fail.

For turbocharger preservation, see section 8.

6.21 Connection of dehumidifiers

Connect and operate the dehumidifiers as described in section 9.

7. Preservation of auxiliary engines

Auxiliary engine preservation must be performed immediately after laying-up the vessel.

Preservation maintenance must be performed regularly during the entire laying-up period and dehumidifier must be connected. See section 9 and 10.

7.1 Lubricating oil system

It is expected that sufficient electric power is available to operate the lubricating oil pump.

Keep the pre-lubricating oil pump operating while turning the crankshaft.

Heating of the lubricating oil is not required during the laying-up period.

Start the lubricating oil purifier and the purifier pre-heater 24 hours before the monthly turning of the crankshaft.

Start the pre-lubricating oil pump one hour before the monthly turning of the crankshaft. Turn the crankshaft 3½ revolutions during the preservation work. Do not turn the crankshaft after the preservation work have been finished.

Once a month, after stopping the purifier, analyse a lubricating oil sample for water content (MAN Diesels' upper limit is 0.2%). Analyse onboard and keep a record of the water content level.

As an alternative it is recommended to use a laboratory to analyse the oil samples for water content.

**MAN B&W****Recommendation**

Info No.: 393 773		Laying-up of Vessels with Engines in Cold Condition	Ident No.: 0 74 35 81 - 8.			
Scale:	Size: A4		Page No.: 15 (42)			
Replacement for Ident. No.:						
Date:	Des.	Chk.	A. C.	Revision change	Chg. Not.	Rev.
20090428	TOB	OLS				0

7.2 Mechanical governor

Follow the governor manufacturer's preservation instructions.

If no preservation instructions are available, the following instructions can be used, for guidance only:

- Exchange the lubricating oil in the governor with new lubricating oil with same property specifications.

7.3 Reciprocating parts on the outside of the engine

Apply rust preservation oil onto all reciprocating parts on the outside of the engine (fuel index rods, fuel-rack links, regulating shaft, etc.).

7.4 Outside machined surfaces

Apply Tectyl 502C onto all machined surfaces on the outside of the engine.

7.5 Valve gear

Remove covers to valve gear and apply preservation oil and remount covers.

7.6 Preservation inside the crankcase

Remove the covers to the crankcase and spray preservation oil onto the surfaces of the inside reciprocating parts, gear wheels and machined surfaces and remount the covers. The dehumidifier must be stopped during the preservation work.

7.7 Preservation of camshaft housing

Remove the covers to the camshaft housing and spray preservation oil onto the camshaft including cams, rollers and roller guides and remount the covers.

7.8 Preservation of cylinder liner, piston crown and piston rings

Dismantle the indicator valves from the cylinder heads and add approximately 1/3 litre of preservation oil into each cylinder. Refit the indicator valves and open the valves. After turning of the crankshaft has finished, close the indicator valves.

Note! For L16/24 without indicator valves (optional), dismantle the fuel injection valves.

7.9 Turbocharger and exhaust pipe

Blank off the connection between the turbocharger outlet to the exhaust pipe with steel plates of 3-5 mm thickness. The purpose of these steel plates is to avoid dust and to protect the turbocharger from rain water if the exhaust system water traps fail. For turbocharger preservation, see section 8.

7.10 Auxiliary engine exhaust pipe and crankcase venting pipe

Cover the auxiliary engine exhaust pipe in the top of the funnel during the laying-up period to protect against rain and dust.

Insert a blind flange between the crankcase and the crankcase venting pipe. This is necessary for the preparation of connecting the dehumidifier.

**MAN B&W****Recommendation**

Info No.: 393 773		Laying-up of Vessels with Engines in Cold Condition	Ident No.: 0 74 35 81 - 8.
Scale:	Size: A4		Page No.: 16 (42)

Replacement for Ident. No.:

Date:	Des.	Chk.	A. C.	Revision change	Chg. Not.	Rev.
20090428	TOB	OLS				0

Should the top of the venting pipe be exposed to rain and dust, it is recommended to cover the venting pipe top.

7.11 Scavenge air receiver

Place a bag of Silica gel inside the scavenge air receiver. It is important to place a collecting tray for water underneath the Silica gel bag to avoid spot corrosion.

7.12 Alternator

During standstill, the alternator heating elements must be connected or similar heating must be established to avoid damp condensation inside the alternator. The heating of the alternator must be continuously operating during the laying-up period.

Corrosion protection must be carried out on machined surfaces, on bearing parts, on the shaft and on bearing gaskets.

The bearings must be filled with protective oil, Mobilarma 524 or similar.

7.13 Connection of dehumidifier

Connect and operate dehumidifier as described in section 9.

8. Turbocharger preservation

Contact the turbocharger manufacturer before dismantling and preservation of the turbocharger.

Follow the turbocharger manufacturer's recommendations.

The following scope of preservation work is for guidance only.

8.1 Preservation

Close the lubricating oil inlet valve or blank off inlet pipe to the turbocharger.

Disassemble the gas admission casing, silencer and insert piece.

Disassemble the rotor, and nozzle ring according to the instruction manual.

Remove deposits on all gas spaces and on turbine inlet and outlet.

Clean the rotor and the nozzle ring with boiling water until all deposits have been removed.

Apply preservation oil to the rotor and the nozzle ring. All surfaces must be dry before applying the preservation oil. The preservation oil must be soluble in the lubricating oil.

Store the rotor and the nozzle ring in a plywood box with a cover in a dry storage place. Make sure that the rotor is supported in the area of the journal bearings only. The supporting area must be covered with a thin metal sheet made of brass. Apply preservation oil before the rotor is placed in the support. The compressor wheel and turbine blades must not have any contact to other parts.

Store the removed casings and silencer in a dry storage place.

**MAN B&W****Recommendation**

Info No.: 393 773		Laying-up of Vessels with Engines in Cold Condition	Ident No.: 0 74 35 81 - 8.			
Scale:	Size: A4		Page No.: 17 (42)			
Replacement for Ident. No.:						
Date:	Des.	Chk.	A. C.	Revision change	Chg. Not.	Rev.
20090428	TOB	OLS				0

Apply preservation oil onto the bearings and inside of the bearing casing and cover all openings.

Blank off the turbine inlet and outlet flanges and compressor flange on the turbocharger casing with steel plates of 3-5mm thickness.

8.2 Maintenance of turbocharger preservation.

Contact the turbocharger manufacturer and follow the turbocharger manufacturer's recommendations.

The following scope of maintenance work is for guidance only:

- Inspect the turbocharger casing and all disassembled parts on a monthly basis. If necessary, apply preservation oil.

8.3 Alternative for the first six months of the laying-up period

As an alternative to dismantle the turbocharger and make the preservation as described in 8.1, the turbocharger can stay assembled for the first six months of the laying-up period. However, the following preparation is required:

Disassemble the gas admission casing and blank off the inlet to the turbine with steel plates of 3-5mm thickness.

Blank off the turbine outlet flanges to the funnel with steel plates of 3-5mm thickness.

Cover the silencer firmly with a tarpaulin.

The lubricating oil inlet must be connected to the turbocharger and lubricating oil inlet valve open.

During the monthly operation of the lubricating oil pump, the cover to the turbine inlet should be dismantled. Inspection can then be made, and the rotor must be turned to distribute lubricating oil evenly in the bearings.

After stopping the lubricating oil pump, inspect and remount the cover.

9. Connection and operation of dehumidifier

9.1 Principles for connecting the dehumidifier and recommended system

The dehumidifiers must be connected to the engine by means of flexible hoses. It is recommended to use steel wire reinforced plastic hoses. Same type as normally used for ventilation systems. The hoses should not be longer than necessary, and sharp bends should be avoided.

It is recommended to use one dehumidifier for circulating the dry air through the scavenge air chamber and exhaust gas receiver (System 1) and one dehumidifier for circulating dry air through the camshaft housing, chain case and crankcase (System 2). If the chain case is placed in the centre of the engine, it is necessary to use two dehumidifiers to circulate the dry air through the camshaft housing, chain case and crankcase (System 2 + System 3)

**MAN B&W****Recommendation**

Info No.: 393 773		Laying-up of Vessels with Engines in Cold Condition	Ident No.: 0 74 35 81 - 8.			
Scale:	Size: A4		Page No.: 18 (42)			
Replacement for Ident. No.:						
Date:	Des.	Chk.	A. C.	Revision change	Chg. Not.	Rev.
20090428	TOB	OLS				0

System 1:

Connect the dry air outlet (process air) from the dehumidifier to a dummy cover placed at the fore-most cleaning cover on the cylinder frame with a flexible hose.

Connect a flexible hose from the aft-most cleaning cover on the cylinder frame to a dummy cover on the aft-end man hole cover of the exhaust gas receiver, or if more than one turbocharger, to the aft-most compensator for the turbocharger of the exhaust gas receiver.

Connect a flexible hose from the fore-most compensator for the turbocharger of the exhaust gas receiver to process air inlet of the dehumidifier.

The dehumidifier should be placed at the top gallery, fore-end.

System 2:

Connect the dry air outlet (process air) from the dehumidifier to a dummy cover placed at the fore-most cover on the camshaft housing with a flexible hose. For ME/ME-C connect to a dummy cover on the chain case.

Connect a flexible hose from a dummy cover at the fore-most relief valve to the process air inlet of the dehumidifier.

The dehumidifiers should be placed at the lower gallery at the manoeuvring side, fore-end.

System 3: (in combination with system 2)

Connect the dry air outlet (process air) from a second dehumidifier of the same size as in system 2 to a dummy cover placed at the aft-most cover on the camshaft housing with a flexible hose. For ME/ME-C, connect to a dummy cover on the chain case.

Connect a flexible hose from a dummy cover at the aft-most relief valve to the process air inlet of the dehumidifier.

The dehumidifiers should be placed at the lower gallery at the manoeuvring side, aft-end.

Note! Keep the hoses of both system 2 and system 3 the same length.

The regenerating air inlet is taking the regenerating air from the engine room.

The regenerating air outlet (wet air) is either led out into the engine room (engine room must be well ventilated), or a hose can be fitted taking the regenerating air to the outside of the engine room. If a hose is fitted discharging the wet air outside, the end of the hose must be carefully fixed and the opening protected against dirt, rain and mechanical damage. Avoid sharp bends and U-bends acting as water locks.

Keep the engine room well-ventilated.

Info No.: 393 773		Laying-up of Vessels with Engines in Cold Condition	Ident No.: 0 74 35 81 - 8.			
Scale:	Size: A4		Page No.: 19 (42)			
Replacement for Ident. No.:						
Date:	Des.	Chk.	A. C.	Revision change	Chg. Not.	Rev.
20090428	TOB	OLS				0

Place the dehumidifiers according to manufacturers recommendation and protect against possible mechanical damage.

Some dehumidifiers must be fitted with orifices according to the manufacturer's recommendation.

Sketch for connecting dehumidifiers, see 9.5.

9.2 Dehumidifier principle and recommended type

There are mainly two dehumidifier principles:

Absorption type:

- The humid air (process air) is circulated in a closed system through an absorber element which dries the air. The absorber element is continuously turned and in another chamber heated air (regenerating air) is blown through the absorber element in order to remove the water from the absorber element. This type is recommended.

Condenser type:

- The humid air (process air) is passing a condenser, where by cooling the air, the water condensate. The condenser type is not as efficient at low temperature as the absorption type and is **not** recommended.

The principle of the recommended absorber type dehumidifier, Figure 6

Figure 6 Examples of dehumidifiers

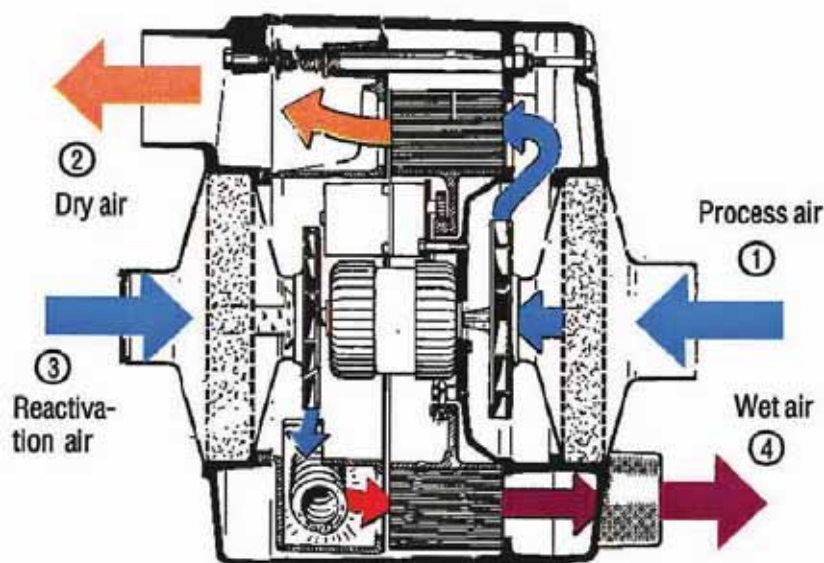

Info No.: 393 773		Laying-up of Vessels with Engines in Cold Condition	Ident No.: 0 74 35 81 - 8.	
Scale:	Size: A4		Page No.: 20 (42)	

Replacement for Ident. No.:						
Date:	Des.	Chk.	A. C.	Revision change	Chg. Not.	Rev.
20090428	TOB	OLS				0

M120 Desiccant Dehumidifier



Product Description

The M120 desiccant dehumidifier is designed to efficiently dehumidify air. Its very compact construction incorporates sections held together by four bolts. The sections contain fans that are driven by a common motor, a direct gear driven desiccant rotor, and a reactivation airflow heater. The two end casings contain distribution chambers with isolated sections that provide a precise balance for dehumidification and reactivation airflows. Its rugged casing is constructed from corrosion resistant die cast aluminium. The electrical control system conforms to EN 60204 (IEC204) standards and the electrical components are assembled in the front compartment. The M120 dehumidifier conforms to both harmonised European Standards and to CE marking specifications.

Munters Rotor Technology

The desiccant rotor is manufactured from a corrugated composite material that is highly effective at attracting and holding water vapour. Every Munters dehumidifier applies a unique rotor technology. Airflows, air conditions, rotor sections, and rotor rotation speeds are optimised for specific applications. An innovative control system maximises the units energy efficiency. A characteristic of the M120 rotor technology is an efficient air distribution chamber which divides the sectors and balances the dehumidification and reactivation airflows.

PRODUCT INFORMATION

M120

Features

- High dehumidification capacity down to -20°C.
- Robust design.
- Shock and vibration proof.
- Humidity plug with low voltage.
- Requires minimal floor area.





MAN B&W

Recommendation

Info No.: 393 773		Laying-up of Vessels with Engines in Cold Condition	Ident No.: 0 74 35 81 - 8.	
Scale:	Size: A4		Page No.: 21 (42)	

Replacement for Ident. No.:						
Date:	Des.	Chk.	A. C.	Revision change	Chg. Not.	Rev.
20090428	TOB	OLS				0

Model M120

Diagram measurements are for reference only.

Scaled and dimensioned AutoCAD drawings are available in Munters' DryCap program.

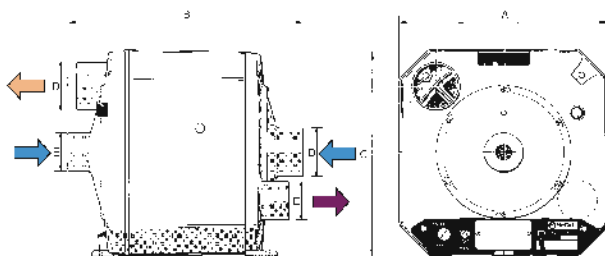

Width (A)	Depth (B)	Height (C)	Diam. (D)	Diam. (E)	Weight
425 mm	481 mm	425 mm	100 mm	80 mm	26 kg

Dehumidification capacity

Approximate capacity in kg/h at different inlet process air relative humidity, % RH.

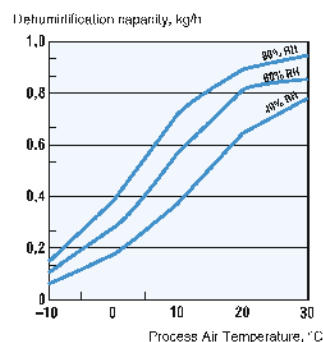

Technical Specification

IEC protective class (electrical panel): IP44

Process air

Freeblowing at 50 Hz (m ³ /h)	150
Freeblowing at 60 Hz (m ³ /h)	210
Rated airflow (m ³ /h)	120
Available static pressure 50 Hz (Pa)	290
Available static pressure 60 Hz (Pa)	360

Reactivation air

Rated airflow (m ³ /h)	35
Available static pressure (Pa)	150

Total power, voltage and current (amps/phase)

Total power (kW)	1.3
115V 1-50Hz (A)	10.9
115V 1-60Hz (A)	11.6
200V 1-50Hz (A)	6.3
200V 1-60Hz (A)	6.6
220V 1-50Hz (A)	5.7
220V 1-60Hz (A)	6.0
230V 1-50Hz (A)	5.7
230V 1-60Hz (A)	6.0
240V 1-50Hz (A)	5.7
240V 1-60Hz (A)	6.0

Miscellaneous data

Operating temperature (°C)	-10/+40
Max noise level unfiltered (dB(A))	68
Air filter standard	G3
IEC protective class (unit)	IP44

Copyright © MAN Diesel, branch of MAN Diesel SE, Germany, registered with the Danish Commerce and Companies Agency under reg. no. CVR 31611792, (herein referred to as "MAN Diesel"). This document is the product and property of MAN Diesel and is protected by applicable copyright laws. This document and anything contained herein shall be treated as confidential by any party to whom it is submitted by MAN Diesel, and it is not to be disclosed to any third party without the specific, prior written permission of MAN Diesel.

AUSTRALIA Tel +61 7 3843 1283 driinfo@munters.com.au	AUSTRIA Tel +43 1 6184290-0 L.f.f.enf.technik@munters.at	BELGIUM Tel +32 3 435 24 37 sa.es@nunters.be	CHINA Tel +86 13 694 18000 info@munters.com.cn	DENMARK Tel +45 7796 3865 info@munters.dk
FINLAND Tel +358 9 3558 033 fi@munters.fi	FRANCE Tel +33 1 3411 3757 fr@munters.fr	GERMANY Tel +49 43 754 601 mge@munters.de	ITALY Tel +39 0153 52 377 marketing@munters.it	JAPAN Tel +81 3 5970 0307 munters@nunters.co.jp
KOREA Tel +82 2 781 8761 munters@munters.co.kr	NETHERLANDS Tel +31 1 42 43 22 91 vacc:nl@nunters.nl	POLAND Tel +48 55 325 01 05 d@nunters.pl	SINGAPORE Tel +65 6744 5520 info@munters.com.sg	SOUTH AFRICA Tel +27 11 997 3300 info@munters.co.za
SPAIN Tel +34 91 640 05 02 munters@munters.es	SWEDEN Tel +46 9 624 0200 sv.ukinfo@munters.se	SWITZERLAND Tel +41 52 2458886 info.dhg@munters.ch	UNITED KINGDOM Tel +44 6796 526 252 d@nunters.co.uk	UNITED STATES Tel +1 378 241 1100 cs@nunters.com





Info No.: 393 773		Laying-up of Vessels with Engines in Cold Condition		Ident No.: 0 74 35 81 - 8.		
Scale:	Size: A4			Page No.: 22 (42)		
Replacement for Ident. No.:						
Date:	Des.	Chk.	A. C.	Revision change	Chg. Not.	Rev.
20090428	TOB	OLS				0

I MADE IN GERMANY I

I TECHNICAL SPECIFICATIONS I ASE 300 I

Desiccant dryer ASE 300

Mode of operation

- The sucked in room air is led by the turning sorption rotor (= process air). The humidity taken up by the rotor is led out by a heated towards air flow (= regeneration air). The air flow is heated by a dynamic, safe and self-regulating PTC heating element. That reg.-air must be led from the room / building.

Rotor ECODRY G3-MH / PTC heater

- The sorption rotor is a High performance rotor, coated with metal silicate optimized for maximum water absorption with different entrance conditions. The rotor offers a very large surface. The mechanical firmness of the surface is extremely high. The rotor is not inflammable, maintenance-free and washable. Dynamic, safe and self-regulating PTC heating element.



Design and dimensions

Area of use

Building drying, water damage drying, dry storage

Set-up/mobility

4 rubber feet (abrasion-resistant and not coloring)
1 carrying handle, above

air inlet

Common air inlet for process- and regeneration-air at the front $\varnothing = 125$ with silencer and air filter

air outlet

dry air: reverse side, $\varnothing = 100$ mm oder 2 x $\varnothing 50$ mm
reg.-air: reverse side, $\varnothing = 80$ mm

Handling

Plug in to power socket, switch on the dehumidifier at the 0/1 switch and set the required humidity on the hygrostat. Guide the reg.-air-outlet-hose (opt. fitting) out of the room / building.

Adjustment of air volumes is not necessary.

dimensions

height / width / depth: (incl. connectors and feet)

370 mm / 335 mm / 430 mm

height / width / depth: (the case only)

323 mm / 335 mm / 360 mm

weight

18 kg

Maintenance

Change filter regularly

Guarantee / manufacturer

2 years from date of purchase, AERIAL made in Germany

General specifications

Capacity / Performance at 20°C / 60% r.h.

Capacity at 20°C / 60% r.h. = 25,70 kg/day

Liter per kW/h = 1,05 l/kWh

kWh/h per Liter = 0,97 kWh / l

air volumes

process air volume: 300 cbm/h

reg.-air volume: 110 cbm/h

Operating range

Temperature: -10 up to +35°C

Humidity: 10 up to 100 %r.h.

noise level

57 dB(A) (in 3 m distance)

Operation panel (let in in the case)

On-/off-switch, incl. hygrostat in the inlet air-flow, kW/h-counter

Case

Durably made of high-grade steel and flux-coated steel sheet. To dismantle very simply, easy to service

electrical connection

- Mains connection:** 1 x 230 V / 50 Hz, cable: 3 mtr with shock-proof-plug

- Fuse:** 10 A slow

- Power consumption:** 1.040 Watts



AERIAL

Version: January 2008 – subject to technical changes.



MAN B&W

Recommendation

Info No.: 393 773		Laying-up of Vessels with Engines in Cold Condition	Ident No.: 0 74 35 81 - 8.	
Scale:	Size: A4		Page No.: 23 (42)	

Replacement for Ident. No.:						
Date:	Des.	Chk.	A. C.	Revision change	Chg. Not.	Rev.
20090428	TOB	OLS				0

9.3 Choosing dehumidifiers

The dehumidifiers must have sufficient capacity to keep the humidity in the engine below 50% RH. The needed capacity of the dehumidifier may vary since the efficiency of the dehumidifier is depending on the ambient temperature and humidity.

When starting the dehumidifiers, the humidity of the air in the engine should be below 50% RH within a maximum of 48 hours. If the humidity of 50% RH is not reached, the system must be investigated and checked if it is connected incorrectly. It is also a possibility that the capacity of the dehumidifiers is insufficient, and it could be necessary to find the proper size of the dehumidifiers by experience.

Note! Capacity of dehumidifiers deviated air at max. 75% RH. If 95% RH the needed capacity might increase around 50%.

For preliminary estimation of the total capacity and numbers of dehumidifiers, the below table can be used:

Capacity and numbers of dehumidifiers:										
		Capacity and numbers of dehumidifiers								
Engine bore:	Number of cylinder	One dehumidifier			Two dehumidifiers			Three dehumidifiers		
		50	90	120	50	90	120	50	90	120
L/S type engines										
26 - 35	5 - 8				2					
					2					
40 - 42	5 - 8		(1)		2					
			(1)		2					
46	5 - 8		(1)		2					
			(1)		2					
50	5 - 9		(1)		2					
			(1)		2					
60	5 - 9		(1)	(1)	2			3		
				(1)		2		2	1	
70	5 - 8			(1)		2		2	1	
				(1)	1	1				
80	6 - 8			(1)	1	1				
						2				
90	6 - 8					2				
						2				
K-type engines										
80				(1)		2				
						(2)		2	1	
90				(1)		2			3	
									3	
98				(1)		2				
									3	

Copyright © MAN Diesel, branch of MAN Diesel SE, Germany, registered with the Danish Commerce and Companies Agency under reg.no. CVR 31611792, (herein referred to as "MAN Diesel"). This document is the product and property of MAN Diesel and is protected by applicable copyright laws. This document and anything contained herein shall be treated as confidential by any party to whom it is submitted by MAN Diesel, and it is not to be disclosed to any third party without the specific, prior written permission of MAN Diesel.

**MAN B&W****Recommendation**

Info No.: 393 773		Laying-up of Vessels with Engines in Cold Condition	Ident No.: 0 74 35 81 - 8.	
Scale:	Size: A4		Page No.: 24 (42)	

Replacement for Ident. No.:

Date:	Des.	Chk.	A. C.	Revision change	Chg. Not.	Rev.
20090428	TOB	OLS				0

9.4 Operation of dehumidifier

To obtain a satisfactory result of the dehumidifying process in the engine, the following items must be optimised:

1. The engine must be effectively sealed, so the dry air is not lost because of leakage, i.e. venting pipe, inspection covers, manholes and doors must be sealed and closed tight
2. The hoses between the engine and the dehumidifiers must be of a good quality and without bends or damages - i.e., the hoses must be shortened, so the lengths of the hoses are as short as possible.
3. The hoses must be connected correctly to the dehumidifiers, and the regeneration air must be led away from the engine (out of the engine room). Care should be taken, that condensing water in the wet regenerating pipe will not enter the dehumidifiers.
4. The dehumidifiers must be in good order, i.e. fitted with orifice if recommended, clean filters, proper hose connections, correct power connection, placed on the gallery of the engine and protected against mechanical damage.
5. The systems must be inspected daily and checked to be in accordance with the above mentioned items.
6. At a daily inspection, the temperature and humidity (and other possible parameters for ensuring correct dehumidifier running) must be measured and recorded. The measurements can be taken from the hose outlet from the engine or by readings from the outlet dummy cover fitted thermometer and hygrometer. If the humidity exceeds 50% RH, the system must be investigated and corrected to ensure proper operation.
7. Measuring the humidity can be done by using a portable hygrometer or by using fixed-fitted hygrometers and thermometers in the outlet dummy covers on the engine. It is recommended to use a portable hygrometer, as the correlation for the many measurements and the required calibration of the measuring tools become easier and more accurate. The hygrometers should be calibrated once a month.
8. On a monthly basis the hole dehumidifier system should be examined and adjusted to optimal condition, i.e., filters, orifices, electric cables, hoses and the connection of the hoses to engine and dehumidifiers.
9. For operation and maintenance of the dehumidifiers, follow the manufacturer's instructions.



MAN B&W

Recommendation

Info No.: 393 773		Laying-up of Vessels with Engines in Cold Condition	Ident No.: 0 74 35 81 - 8.	
Scale:	Size: A4		Page No.: 25 (42)	

Replacement for Ident. No.:						
Date:	Des.	Chk.	A. C.	Revision change	Chg. Not.	Rev.
20090428	TOB	OLS				0

9.5 Sketch for connecting dehumidifiers

Figure 7 Diagrams of connection of dehumidifier (for clarification follow the text in 9.1)

System 1 View from manoeuvring side

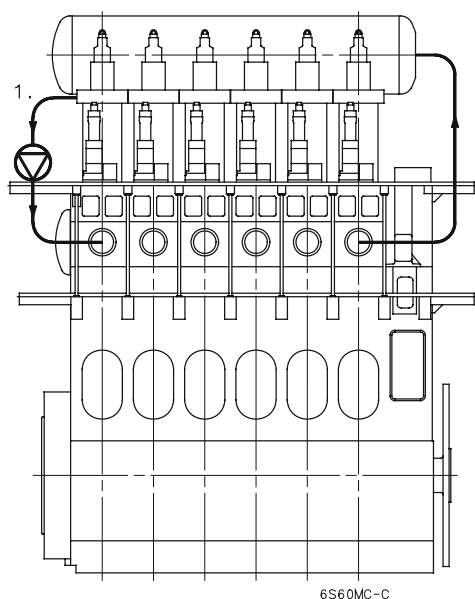

System 1 View from exhaust side

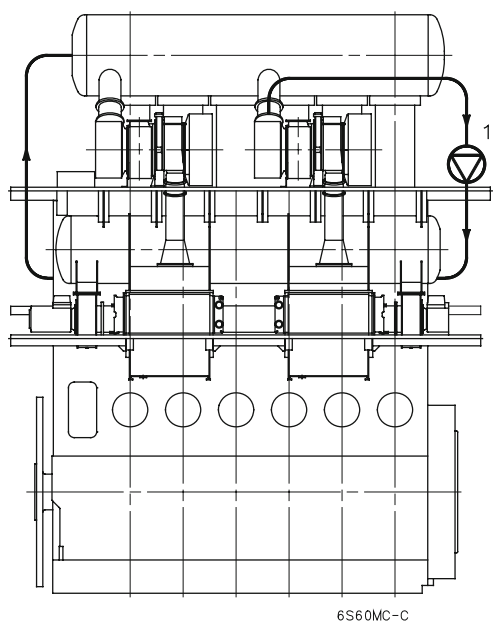

Copyright © MAN Diesel, branch of MAN Diesel SE, Germany, registered with the Danish Commerce and Companies Agency under reg. no. CVR 31611792, (herein referred to as "MAN Diesel"). This document is the product and property of MAN Diesel and is protected by applicable copyright laws. This document and anything contained herein shall be treated as confidential by any party to whom it is submitted by MAN Diesel, and it is not to be disclosed to any third party without the specific, prior written permission of MAN Diesel.



MAN B&W

Recommendation

Info No.: 393 773		Laying-up of Vessels with Engines in Cold Condition	Ident No.: 0 74 35 81 - 8.	
Scale:	Size: A4		Page No.: 26 (42)	

Replacement for Ident. No.:						
Date:	Des.	Chk.	A. C.	Revision change	Chg. Not.	Rev.
20090428	TOB	OLS				0

System 2 View from manoeuvring side

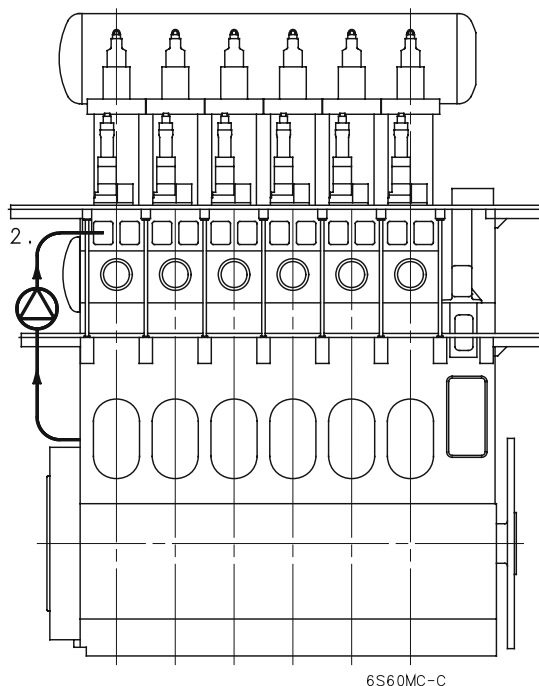

System 2 View from exhaust side

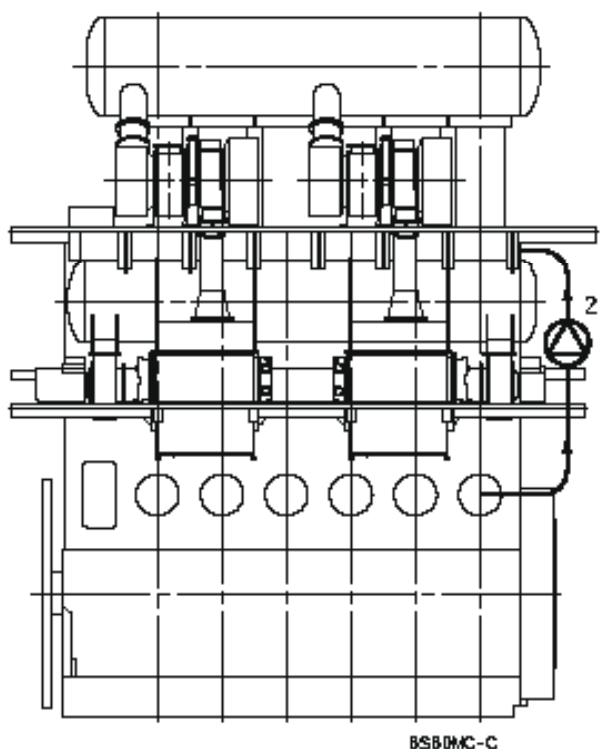

Copyright © MAN Diesel, branch of MAN Diesel SE, Germany, registered with the Danish Commerce and Companies Agency under reg. no. CVR 31611792, (herein referred to as "MAN Diesel").
This document is the product and property of MAN Diesel and is protected by applicable copyright laws. This document and anything contained herein shall be treated as confidential by any party to whom it is submitted by MAN Diesel, and it is not to be disclosed to any third party without the specific, prior written permission of MAN Diesel.



MAN B&W

Recommendation

Info No.: 393 773		Laying-up of Vessels with Engines in Cold Condition	Ident No.: 0 74 35 81 - 8.	
Scale:	Size: A4		Page No.: 27 (42)	

Replacement for Ident. No.:						
Date:	Des.	Chk.	A. C.	Revision change	Chg. Not.	Rev.
20090428	TOB	OLS				0

System 1 (ME/ME-C) View from manoeuvring side

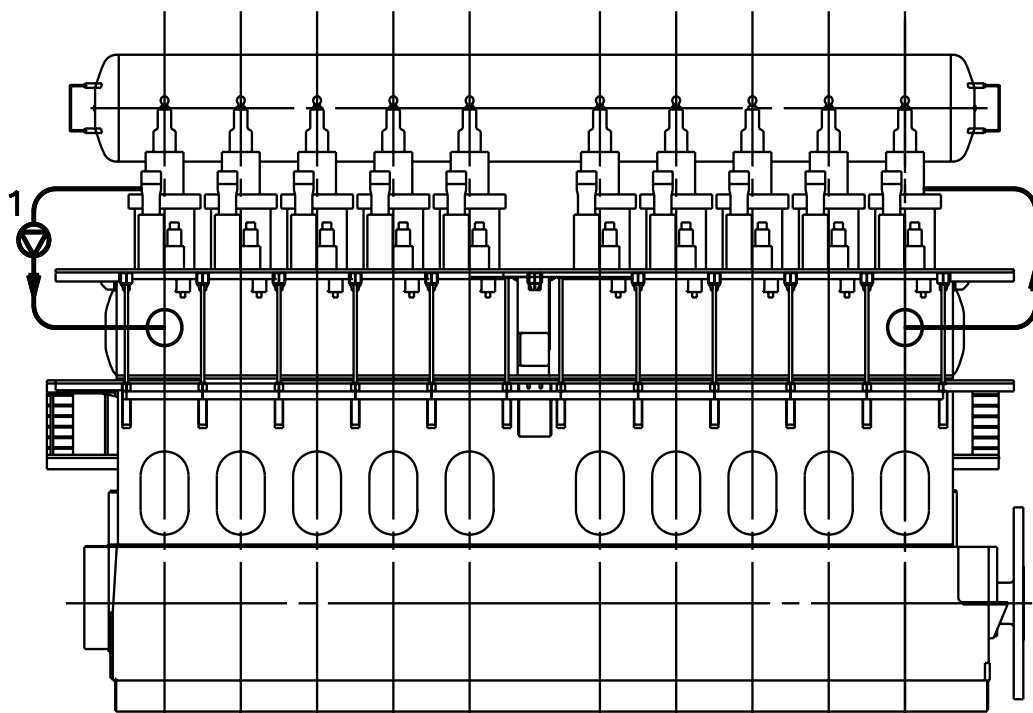

System 1 (ME/ME-C) View from exhaust side

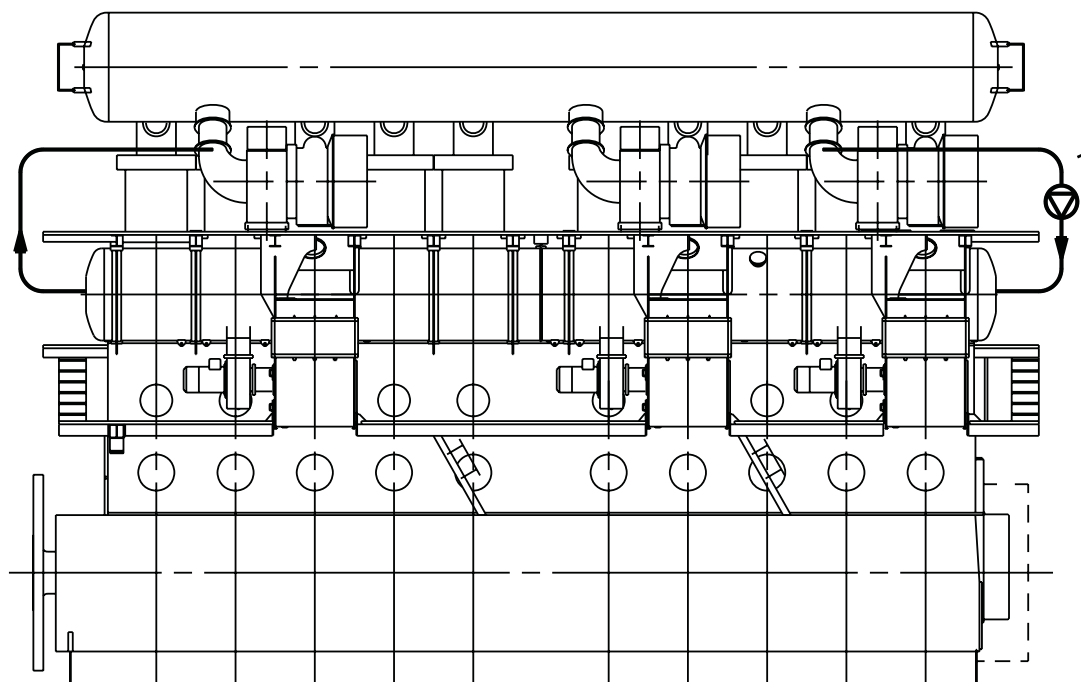

Copyright © MAN Diesel, branch of MAN Diesel SE, Germany, registered with the Danish Commerce and Companies Agency under reg. no. CVR 31611792, (herein referred to as "MAN Diesel").
 This document is the product and property of MAN Diesel and is protected by applicable copyright laws. This document and anything contained herein shall be treated as confidential by any party to whom it is submitted by MAN Diesel, and it is not to be disclosed to any third party without the specific, prior written permission of MAN Diesel.



MAN B&W

Recommendation

Info No.: 393 773		Laying-up of Vessels with Engines in Cold Condition	Ident No.: 0 74 35 81 - 8.	
Scale:	Size: A4		Page No.: 28 (42)	

Replacement for Ident. No.:						
Date:	Des.	Chk.	A. C.	Revision change	Chg. Not.	Rev.
20090428	TOB	OLS				0

System 2+3 (ME/ME-C) View from manoeuvring side

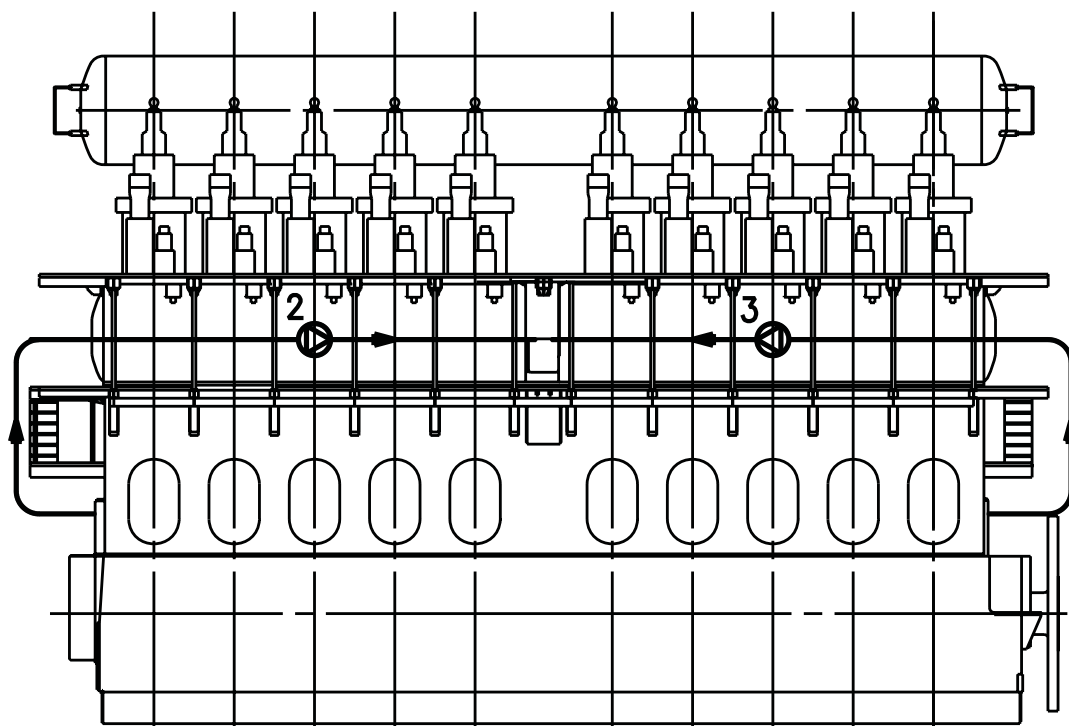

System 2+3 (ME/ME-C) View from exhaust side

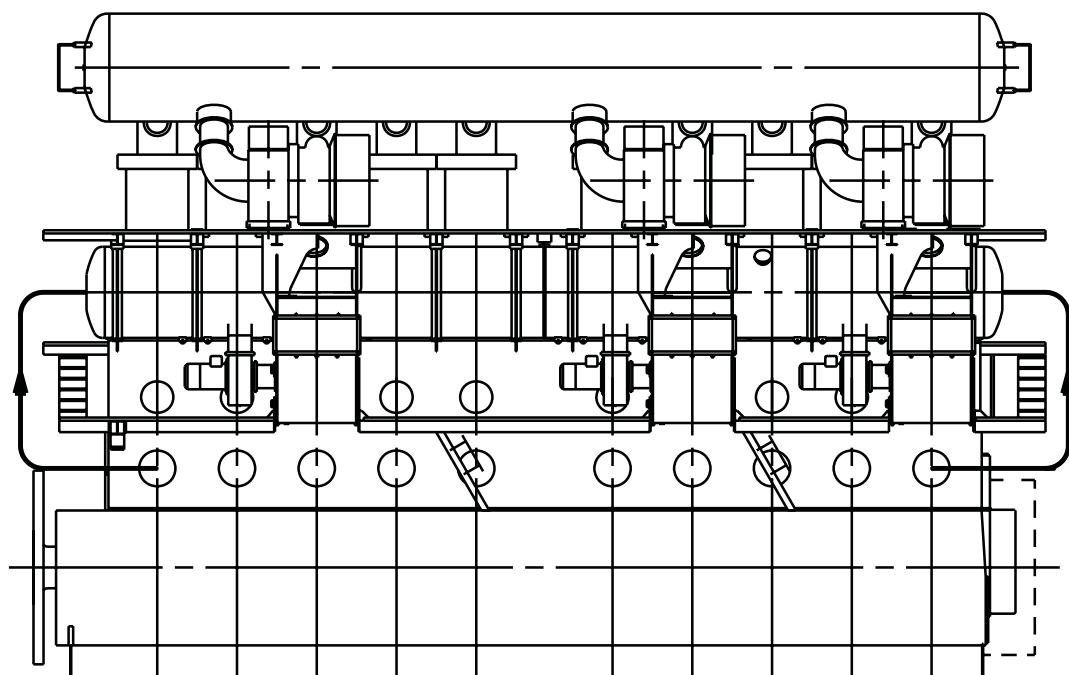

Copyright © MAN Diesel, branch of MAN Diesel SE, Germany, registered with the Danish Commerce and Companies Agency under reg. no. CVR 31611792, (herein referred to as "MAN Diesel").
This document is the product and property of MAN Diesel and is protected by applicable copyright laws. This document and anything contained herein shall be treated as confidential by any party to whom it is submitted by MAN Diesel, and it is not to be disclosed to any third party without the specific, prior written permission of MAN Diesel.

Info No.: 393 773		Laying-up of Vessels with Engines in Cold Condition	Ident No.: 0 74 35 81 - 8.	
Scale:	Size: A4		Page No.: 29 (42)	

Replacement for Ident. No.:						
Date:	Des.	Chk.	A. C.	Revision change	Chg. Not.	Rev.
20090428	TOB	OLS				0

Figure 8 Dummy cover

Example of mounting hygrometer and thermometer in the dummy cover for de-humiditing air outlet from the engine

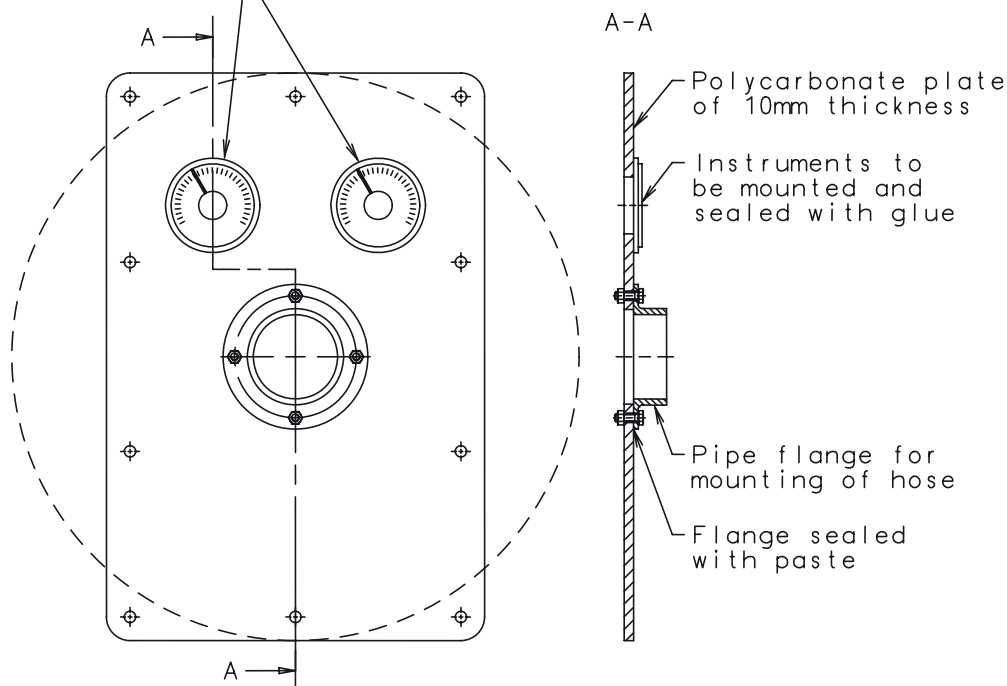



MAN B&W

Recommendation

Info No.: 393 773		Laying-up of Vessels with Engines in Cold Condition	Ident No.: 0 74 35 81 - 8.	
Scale:	Size: A4		Page No.: 30 (42)	

Replacement for Ident. No.:						
Date:	Des.	Chk.	A. C.	Revision change	Chg. Not.	Rev.
20090428	TOB	OLS				0

Figure 9 Recording sheet

Date	Total hour	(C) temp	(%) humidity	Date	Total hour	(C) temp	(%) humidity

Copyright © MAN Diesel, branch of MAN Diesel SE, Germany, registered with the Danish Commerce and Companies Agency under reg. no. CVR 31611792, (herein referred to as "MAN Diesel").
This document is the product and property of MAN Diesel and is protected by applicable copyright laws. This document and anything contained herein shall be treated as confidential by any party to whom it is submitted by MAN Diesel, and it is not to be disclosed to any third party without the specific, prior written permission of MAN Diesel.



MAN B&W

Recommendation

Info No.: 393 773		Laying-up of Vessels with Engines in Cold Condition	Ident No.: 0 74 35 81 - 8.	
Scale:	Size: A4		Page No.: 31 (42)	

Replacement for Ident. No.:						
Date:	Des.	Chk.	A. C.	Revision change	Chg. Not.	Rev.
20090428	TOB	OLS				0

10. Connection of dehumidifier for the auxiliary engines.

For dehumidifying the auxiliary engines, one dehumidifier of the size of 50 m³/h rated air should be sufficient. (See table in paragraph 9).

The dehumidifier and auxiliary engines are to be connected with hoses as shown in Figure 10 and Figure 11.

Figure 10

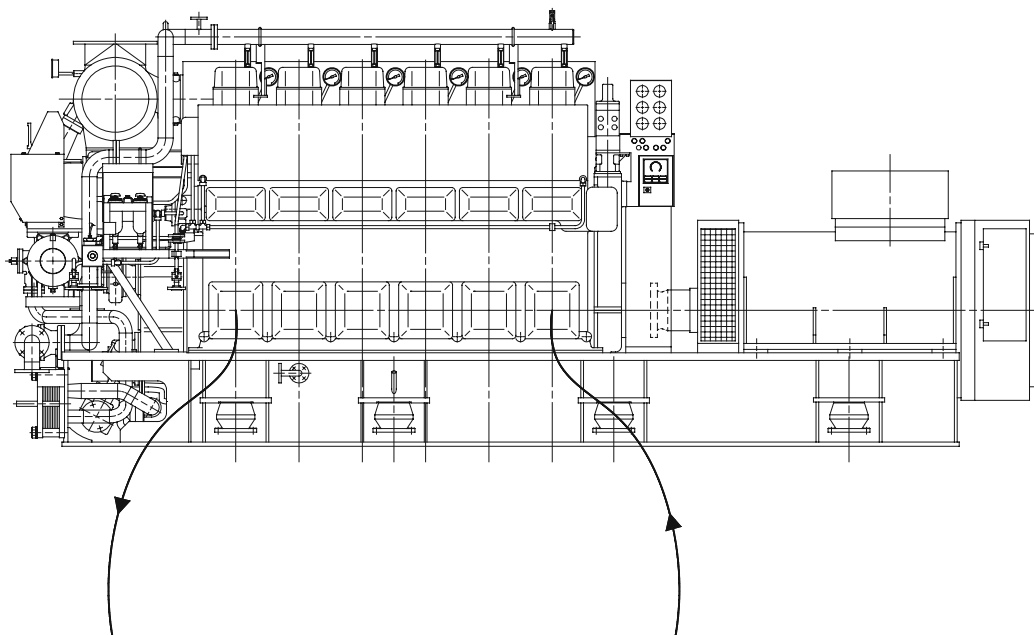

Replace the first and last cover of the crankcase with dummy covers for connecting the hoses to the dehumidifier.

Copyright © MAN Diesel, branch of MAN Diesel SE, Germany, registered with the Danish Commerce and Companies Agency under reg. no. CVR 31611792, (herein referred to as "MAN Diesel").
This document is the product and property of MAN Diesel and is protected by applicable copyright laws. This document and anything contained herein shall be treated as confidential by any party to whom it is submitted by MAN Diesel, and it is not to be disclosed to any third party without the specific, prior written permission of MAN Diesel.



MAN B&W

Recommendation

Info No.: 393 773		Laying-up of Vessels with Engines in Cold Condition	Ident No.: 0 74 35 81 - 8.	
Scale:	Size: A4		Page No.: 32 (42)	

Replacement for Ident. No.:						
Date:	Des.	Chk.	A. C.	Revision change	Chg. Not.	Rev.
20090428	TOB	OLS				0

Figure 11

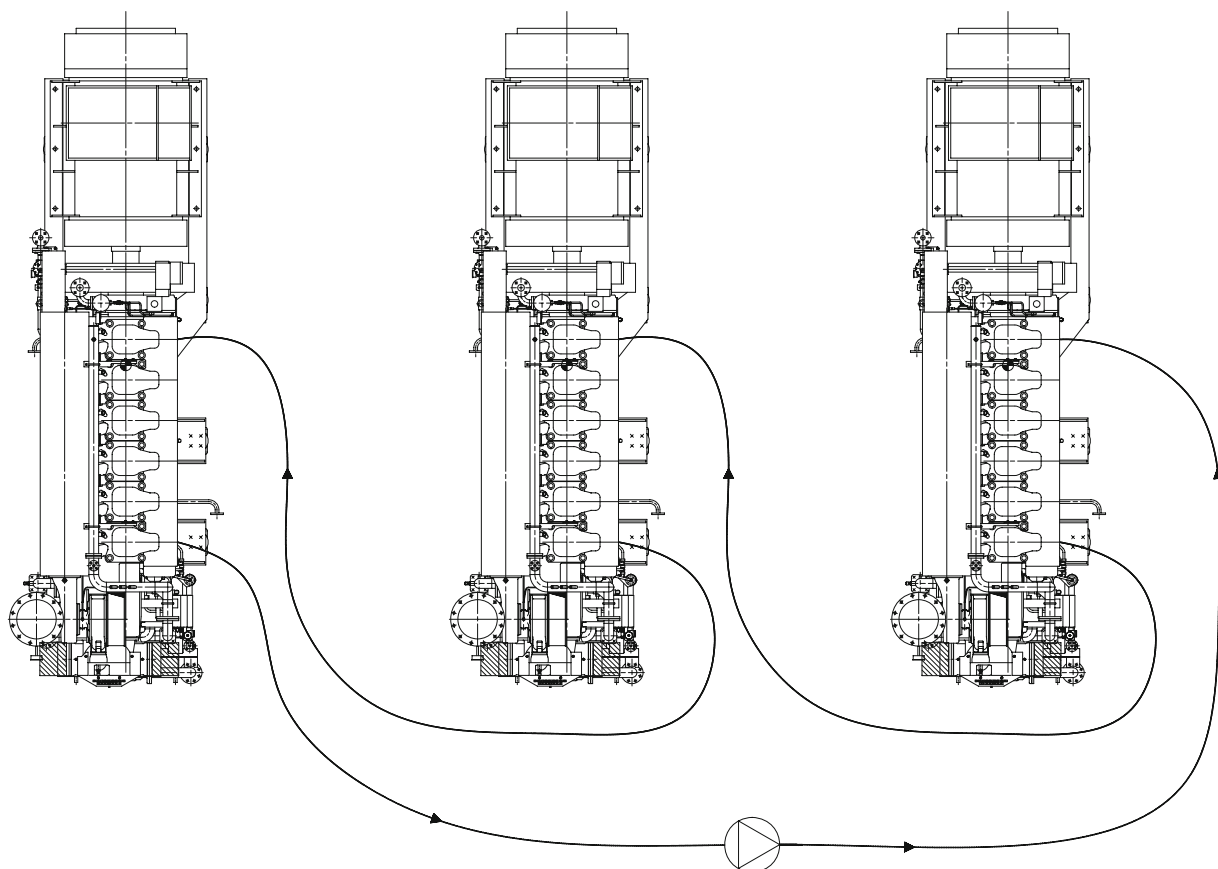

Connecting the hoses of three auxiliary engines to the dehumidifier.

Copyright © MAN Diesel, branch of MAN Diesel SE, Germany, registered with the Danish Commerce and Companies Agency under reg. no. CVR 31611792, (herein referred to as "MAN Diesel").
This document is the product and property of MAN Diesel and is protected by applicable copyright laws. This document and anything contained herein shall be treated as confidential by any party to whom it is submitted by MAN Diesel, and it is not to be disclosed to any third party without the specific, prior written permission of MAN Diesel.



Info No.: 393 773		Laying-up of Vessels with Engines in Cold Condition	Ident No.: 0 74 35 81 - 8.			
Scale:	Size: A4		Page No.: 33 (42)			
Replacement for Ident. No.:						
Date:	Des.	Chk.	A. C.	Revision change	Chg. Not.	Rev.
20090428	TOB	OLS				0

11. Protection of electronic equipment

It is recommended to keep the cabinets for electronic equipment closed during the laying-up period to protect against mechanical damage of the electronics, dirt and static electricity.

11.1 Electronic equipment on the main engine

Vapour corrosion control must be applied inside all cabinets for electronic equipment. Install capsules according to lifespan and protective range of a capsule, see Figure 3.

All cabinets for electronic equipment must be closed and cable glands must be tight. Open holes in cabinets must be sealed air tight.

11.2 Electronic equipment in the control room

Air conditioning must be operating permanently to keep the temperature between 20 - 25 °C. The humidity of the air should be kept between 40-50 % RH.

11.3 Examples of vapour corrosion control suppliers

www.cortecvci.com

Model: Cortec VpCI 101

Description: Impregnated foam device

Silica gel desiccant packs

www.zerust.co.uk

Model: Zerust Capsules, see lifespan and protective range Figure 6.

Description: Designed to protect electronic components inside of enclosures

11.4 Protection during maintenance and repair works

All cabinets for electronic equipment must be closed and holes sealed air tight when grinding, welding, painting or cleaning is carried out on the engine or close to the engine.

If welding on the engine is necessary, the ground clamp cable must have good electrical contact and should be placed as close to the welding arc as possible. The welding power supply must have an adequate earthing device.



Info No.: 393 773		Laying-up of Vessels with Engines in Cold Condition	Ident No.: 0 74 35 81 - 8.
Scale:	Size: A4		Page No.: 34 (42)

Replacement for Ident. No.:						
Date:	Des.	Chk.	A. C.	Revision change	Chg. Not.	Rev.
20090428	TOB	OLS				0

Figure 12

ZERUST® interior surface protection

How ZERUST® Vapor Capsules work

Corrosion protection for metals in switch gearboxes, electronic cabinets and other enclosures.

- When removed from its sealed package and placed in an enclosure, a capsule will saturate the surrounding atmosphere with an invisible, odourless, non toxic vapour. The ZERUST® vapour molecules will then form a protective corrosion inhibiting layer on all exposed metal surfaces in a cabinet, package or container.
- Upon removal of the capsule, the protective layer will revapourise, leaving all surfaces clean, dry, and without any residues.

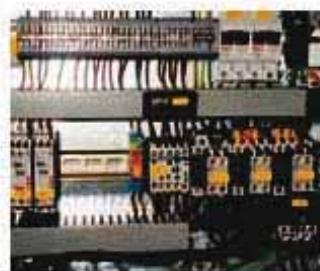

Installation

ZERUST® Vapor Capsules are easily installed in a few seconds without tools or specialised labour. Simply peel the cover tape from the adhesive backing to attach to most surfaces.

Reduce maintenance costs

ZERUST® Vapor Capsules prevent the oxidation that causes increasingly higher levels of electrical resistance. This, as well as the longevity of the capsule, allows for fewer maintenance checks, reduced down time and component failures, in comparison to alternative protection methods.

Use ZERUST® capsules

- During shipment and initial storage, often combined with ZERUST® Valeno packaging.
- During normal operation.
- During closure, storage or shutdown.

ZERUST® Capsules offer Multi-Metal protection:

Steel and iron, zinc and galvanized steel, copper, brass, bronze, aluminium (and its alloys), nickel, tin, solder.

Lifespan and protective range of a ZERUST® Capsule

Item	Protective radius	Protective volume	Protective lifetime
VC0.5-1	30 cm	0.1 m ³	1 year
VC1-1	30 cm	0.1 m ³	1 year
VC2-1	60 cm	1.0 m ³	1 year
VC2-2	60 cm	1.0 m ³	2 years
VC5-1	180 cm	25.0 m ³	1 year
VC5-2	180 cm	25.0 m ³	2 years

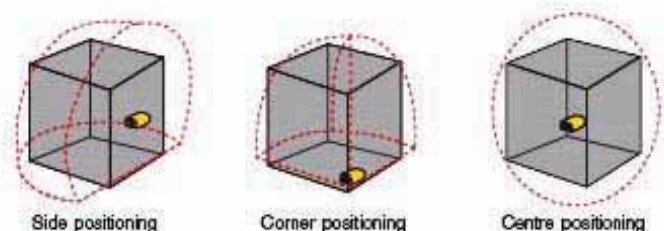



Info No.: 393 773		Laying-up of Vessels with Engines in Cold Condition	Ident No.: 0 74 35 81 - 8.			
Scale:	Size: A4		Page No.: 35 (42)			
Replacement for Ident. No.:						
Date:	Des.	Chk.	A. C.	Revision change	Chg. Not.	Rev.
20090428	TOB	OLS				0

12. Equipment for preservation oil spraying

It is recommended to use an oil sprayer to apply preservation oil onto the components inside the engine. A portable oil sprayer, ex. type ME3610FSP from MESTO (Figure 13) or similar, is recommended. The oil sprayer can be charged with 6 bar compressed air and if compressed air is not available in the engine room when the maintenance of the preservation of the engines are to be carried out, a small portable compressor can be handy.

During the preservation work, it is recommended to wear, oil resistant gloves, eye protection, respiratory protection equipment, proper clothing and safety shoes.

Normal safety precautions and procedures should be followed when entering the engine.

Figure 13 Oil sprayer from MESTO, www.mesto.de, type ME3610FSP



13. Maintenance of main engine preservation

Regular preservation maintenance is necessary during the entire laying-up period.

13.1 Visual inspection (monthly)

Inspect the entire engine inside and outside, without turning the crankshaft, to reveal any corrosion or water contamination. Remove signs of corrosion, if any. Clean up after removing. Apply preservation oil to the inspected components.

**MAN B&W****Recommendation**

Info No.: 393 773		Laying-up of Vessels with Engines in Cold Condition	Ident No.: 0 74 35 81 - 8.	
Scale:	Size: A4		Page No.: 36 (42)	

Replacement for Ident. No.:

Date:	Des.	Chk.	A. C.	Revision change	Chg. Not.	Rev.
20090428	TOB	OLS				0

Inspect the engine components for corrosion, particularly cylinder liners, piston rods, cross head, guide rails and chaindrive.

Remove signs of corrosion, if any. Clean up after removing. Apply preservation oil to the components.

Inspect the upper parts of piston crowns, piston ring packs and cylinder liner from the inside of the scavenge air receiver through the scavenge air ports.

Inspect the inside of the camshaft housing, camshaft, cams, rollers and roller-guides.

13.2 Engine components and turning of crankshaft (monthly)

Inspect the entire inside of the engine before starting the main lubricating oil pumps and camshaft lubricating oil pumps (if any).

To prevent corrosion of engine components which are not directly accessible for visual inspection, i.e. bearings, journals, cylinder liners, piston rings, etc., and to avoid the crankshaft to settle in the same position, turn the crankshaft 3½ revolutions once a month.

The main lubricating oil system must be operated for one hour, lubricating oil purifiers and pre-heaters for 24 hours before the crankshaft is turned.

Note! Stop and disconnect the dehumidifier before starting the lubricating oil pump, during crankcase inspection before turning and when turning the crankshaft. Reconnect and operate the dehumidifier immediately after applying preservation oil and closing the crankcase doors.

Preservation of the scavenge air chamber, including cylinder liners, pistons rods and piston crowns

Spray preservation oil onto the cylinder liner walls and piston crowns through the scavenge air ports when the pistons are in bottom position.

Fill the top of the piston crowns with a special type of vaporising preservation oil. This will protect the inside of the cylinder covers.

Spray preservation oil onto the piston rings when passing the scavenge air ports while turning the crankshaft.

Repeat once for each cylinder. From start to finish of this procedure, the crankshaft must be turned exactly 3½ revolutions in all.

After the turning has been completed, spray the piston rods, stuffing boxes and the outside of the cylinder liner with preservation oil.

Preservation inside the crankcase

Stop the main lubricating oil pumps and purifiers after completing crankshaft turning. Let the lubricating oil drain off for a minimum of one hour. Spray preservation oil onto the surfaces of inside reciprocating parts, guide rails, chaindrive, chain wheels, etc. Close the crankcase doors tightly.

**MAN B&W****Recommendation**

Info No.: 393 773		Laying-up of Vessels with Engines in Cold Condition	Ident No.: 0 74 35 81 - 8.			
Scale:	Size: A4		Page No.: 37 (42)			
Replacement for Ident. No.:						
Date:	Des.	Chk.	A. C.	Revision change	Chg. Not.	Rev.
20090428	TOB	OLS				0

Preservation of camshaft housing

Inspect the camshaft before starting the camshaft lubricating oil pumps prior to preservation of the components inside the engine.

If the engine has a separate camshaft lubricating oil system, run the camshaft lubricating oil pump (cold oil) to circulate the lubricating oil through the system while the main lubricating oil pumps are running (one hour). Do not stop the pumps until the crankshaft turning procedure has been completed.

Let the lubricating oil drain off for a minimum of one hour after stopping the lubricating oil pumps. Dismantle the camshaft housing covers and spray rust preventing oil onto the camshaft including cams, rollers and roller-guides. Remount the housing covers.

After completing the monthly turning and preservation procedure

After stopping the purifier, analyse oil samples from the main lubricating oil and camshaft lubricating oil/hydraulic power supply oil (ME/ME-C/ME-B) for water content (MAN Diesel's upper limit is 0.2%). Analyse onboard and keep a record of the water content level.

As an alternative, it is recommended to use a laboratory to analyse the oil samples for water content.

13.3 Hydraulic power supply oil system (monthly)

ME/ME-C and ME-B engines:

During the monthly running of main lubricating oil pumps, run the start-up pumps (cold oil) for one hour to pressure rise the lubricating oil in the HPS system. Make a visual inspection of the HPS system.

13.4 Reciprocating parts on the outside of the engine (monthly or as required)

Apply rust preservation oil onto all reciprocating parts on the outside of the engine (fuel index rods, VIT index rods and fuel-rack links, etc.).

13.5 Outside machined surfaces (monthly or as required)

Apply Tectyl 502C onto all machined surfaces on the outside of the engine.

13.6 Crankcase relief valves (monthly or as required)

Follow the maintenance instruction from the manufacturer.

If no information is available related to the rust protection of the relief valve, it can be recommended to spray the flame arrester steel plates with preservation oil, Dinitrol 40 or similar.

Only cover the relief valve with proper protection in the event that painting, welding or grinding work is taking place nearby which can damage the relief valve.

13.7 Auxiliary blowers

Keep the electrical heating of the auxiliary blower motors operating continuously.

Copyright © MAN Diesel, branch of MAN Diesel SE, Germany, registered with the Danish Commerce and Companies Agency, under reg. no. CVR 31611792, (herein referred to as "MAN Diesel"). This document is the product and property of MAN Diesel and is protected by applicable copyright laws. This document and anything contained herein shall be treated as confidential by any party to whom it is submitted by MAN Diesel, and it is not to be disclosed to any third party without the specific, prior written permission of MAN Diesel.

**MAN B&W****Recommendation**

Info No.: 393 773		Laying-up of Vessels with Engines in Cold Condition	Ident No.: 0 74 35 81 - 8.			
Scale:	Size: A4		Page No.: 38 (42)			
Replacement for Ident. No.:						
Date:	Des.	Chk.	A. C.	Revision change	Chg. Not.	Rev.
20090428	TOB	OLS				0

13.8 Main starting air pipe (monthly)

Replace the dehumidifying vapour powder in the main starting air pipe.

13.9 Exhaust gas receiver (monthly)

Inspect the exhaust gas receiver.

13.10 Dehumidifier (daily, monthly)**Daily!**

Record the humidity, temperature and operating hours of dehumidifying process in the maintenance log book. The readings are to be taken either from the outlet hoses or from the permanently fitted hygrometer and thermometer, for the camshaft housing (if any), crankcase and scavenge air chamber.

If the humidity in the engine exceeds 50% RH, check the dehumidifier.

For operation and maintenance of the dehumidifier, follow the manufacturer's instructions.

Diagram for connection of dehumidifier and recording sheet. Figures 7, 8 and 9 (section 9).

Monthly!

Calibrate the hygrometers.

13.11 Spare parts and maintenance tools (as required)

Inspect spare parts and maintenance tools regularly.

13.12 Intermediate shaft and stern tube bearings (monthly)

Prior to the monthly crankshaft turning, ensure that all bearings in the propeller shaft system are lubricated.

14. Maintenance of auxiliary engine preservation.**14.1 Lubricating oil system (monthly)**

Start the lubricating oil purifier and the purifier pre-heater 24 hours before the monthly turning of the crankshaft.

Start the pre-lubricating oil pump one hour before the turning of the crankshaft. Keep the pre-lubricating oil pump operating while turning. Heating of the lubricating oil is not required during the laying-up period.

Turn the crankshaft 3½ revolutions during the preservation work. Do not turn the crankshaft after the preservation work has been finished.

Once a month after stopping the purifier analyse a lubricating oil sample for water content (MAN Diesel's upper limit is 0.2%). Analyse onboard and keep a record of the water content level.

As an alternative, it is recommended to use a laboratory to analyse the oil samples for water content.

Copyright © MAN Diesel, branch of MAN Diesel SE, Germany, registered with the Danish Commerce and Companies Agency under reg.no. CVR 31611792, (herein referred to as "MAN Diesel"). This document is the product and property of MAN Diesel and is protected by applicable copyright laws. This document and anything contained herein shall be treated as confidential by any party to whom it is submitted by MAN Diesel, and it is not to be disclosed to any third party without the specific, prior written permission of MAN Diesel.

**MAN B&W****Recommendation**

Info No.: 393 773		Laying-up of Vessels with Engines in Cold Condition	Ident No.: 0 74 35 81 - 8.
Scale:	Size: A4		Page No.: 39 (42)

Replacement for Ident. No.:

Date:	Des.	Chk.	A. C.	Revision change	Chg. Not.	Rev.
20090428	TOB	OLS				0

14.2 Mechanical governor (once every six months)

Follow the governor manufacturer's preservation instructions.

If no preservation instructions are available, the following instructions can be used, for guidance only:

Exchange the lubricating oil in the governor with new lubricating oil with same property specifications.

14.3 Reciprocating parts on the outside of the engine (monthly)

Inspect and apply rust preservation oil onto all reciprocating parts on the outside of the engine (fuel index rods, fuel-rack links, regulating shaft, etc.).

14.4 Outside machined surfaces (monthly)

Inspect all machined surfaces on the outside of the engine and apply Tectyl 502C if necessary.

14.5 Valve gear (monthly)

Remove covers and inspect the valve gear and apply preservation oil and remount covers.

14.6 Preservation inside the crankcase (monthly)

Inspect the inside of the crankcase before starting the pre-lubricating oil pump.

Start the pre-lubricating oil pump one hour before the turning of the crankshaft. Turn the crankshaft 3½ revolutions during the preservation work.

Spray preservation oil onto the surfaces of the inside reciprocating parts, gear wheels and machined surfaces and remount the covers. Do not turn the crankshaft after the preservation work of the crankcase have been finished.

Note! Stop and disconnect the dehumidifier before, starting the pre-lubricating oil pump, during crankcase inspection, before turning and when turning the crankshaft.

Reconnect and operate the dehumidifier immediately after applying preservation oil and the covers have been remounted.

14.7 Preservation of camshaft housing (monthly)

Remove the covers to the camshaft housing, make inspection and spray preservation oil onto the camshaft including cams, rollers and roller guides while turning the crankshaft and remount the covers.

14.8 Preservation of cylinder liner, piston crown and piston rings (monthly)

Dismantle the indicator valves from the cylinder heads and add approximately 1/3 litre of preservation oil into each cylinder. Refit the indicator valves and open the valves. After turning of the crankshaft has finished, close the indicator valves.

Note! For L16/24 without indicator valves (optional), dismantle the fuel injection valves.

**MAN B&W****Recommendation**

Info No.: 393 773		Laying-up of Vessels with Engines in Cold Condition	Ident No.: 0 74 35 81 - 8.			
Scale:	Size: A4		Page No.: 40 (42)			
Replacement for Ident. No.:						
Date:	Des.	Chk.	A. C.	Revision change	Chg. Not.	Rev.
20090428	TOB	OLS				0

14.9 Dehumidifier (daily, monthly)**Daily!**

Record the humidity, temperature and operating hours of the dehumidifying process in the maintenance log book. The readings are to be taken either from the outlet hoses or from the hygrometer and thermometer fitted permanently in the outlet dummy cover of the crankcase.

If the humidity in the engine exceeds 50% RH, check the dehumidifier.

For operation and maintenance of the dehumidifier, follow the manufacturer's instructions.

Diagram for connection of dehumidifier and recording sheet, see Figs. 1 and 2.

Monthly!

Calibrate the hygrometers.

14.10 Scavenge air receiver (monthly)

Replace the bag of Silica gel inside the scavenge air receiver. Empty the collecting tray for water.

14.11 Jacket cooling water system (monthly)

Circulate the cooling water for one hour.

14.12 Central cooling water system (monthly)

Circulate the cooling water for one hour.

14.13 Auxiliary engine exhaust pipe

Inspect the top cover of the funnel for the exhaust pipe of the of the auxiliary engine on a regular basis.

14.14 Alternator

Inspect the alternator on a regular basis and ensure that the heating elements are operating proper.

14.15 Maintenance tools and spare parts

Inspect the maintenance tools and spare parts for the auxiliary engine on a regular basis.

15. Preparation of turbocharger before recommencing service

Contact the turbocharger manufacturer before commissioning the turbocharger.

The following scope of work is for guidance only:

Disassemble the blanking plates and remove all covers.

Clean out the preservation oil and inspect the casing, bearings, rotor and nozzle ring.

**MAN B&W****Recommendation**

Info No.: 393 773		Laying-up of Vessels with Engines in Cold Condition	Ident No.: 0 74 35 81 - 8.
Scale:	Size: A4		Page No.: 41 (42)

Replacement for Ident. No.:

Date:	Des.	Chk.	A. C.	Revision change	Chg. Not.	Rev.
20090428	TOB	OLS				0

Apply lubricating oil onto the bearings and mount the rotor and nozzle ring according to the instruction manual.

Assemble the turbocharger casings and silencer according to the instruction manual.

Assemble the turbocharger gas inlet pipe.

Reconnect the lubricating oil inlet.

Follow the starting up instructions in the turbocharger and engine instruction manual.

16. Starting the main engine after the laying-up period

Uninstall the dehumidifier. Remove the dehumidifying vapour powder from the main starting air pipe.

Clean the outside of the engine.

Before starting the main engine, clean out any rust preservation oil deposits in the scavenge boxes, scavenge air receiver and the piston crowns.

Clean the top of the piston crowns. Check carefully that any preservation oil residuals are removed from the piston crown tops before starting the engine

Clean, inspect, and pressure test the fuel valves. Inspect the fuel pumps.

Remove the steel blanking plates from the exhaust gas receiver outlet and turbocharger gas outlet to funnel.

Reassemble the turbocharger according to the instruction manual.

Remove the cover from the top of the funnel.

Verification of correct function of engine safety systems (shut down/slow down) must be carried out prior to the first start. For MC/MC-C engines, it is recommend that the first start is performed from the local engine side manoeuvring console. For ME/ME-C/ME-B engines, it is recommended to perform the first start from the control room control, since the local operation panel is also electronically operated.

We emphasise the importance of supplying control air to the exhaust valves in due time prior to first start in order to force out the preservation oil from the air spring chambers (see part 6.5 Exhaust valve).

All items in the "laying-up check list" (as mentioned in paragraph 1) must be brought back to normal service condition prior to start of the engine.

Reference is also made to our instruction manual, particularly the chapters "Check during standstill periods" and "Preparations for starting".



Info No.: 393 773		Laying-up of Vessels with Engines in Cold Condition	Ident No.: 0 74 35 81 - 8.			
Scale:	Size: A4		Page No.: 42 (42)			
Replacement for Ident. No.:						
Date:	Des.	Chk.	A. C.	Revision change	Chg. Not.	Rev.
20090428	TOB	OLS				0

17. Starting the auxiliary engines after the laying-up period

Uninstall the dehumidifier.

Clean the outside of the engine.

Remove the Silica gel bag and inspect the scavenge air receiver.

Check carefully that any preservation oil residuals are removed from the piston crown tops before starting the engine by opening the indicator valves and turn the crankshaft by turning gear minimum one revolution. Then blast the cylinders clean by turning the crankshaft with the starter motor.

Clean, inspect, and pressure test the fuel valves. Inspect the fuel pumps.

Remove the steel blanking plate from the turbocharger gas outlet to funnel.

Reassemble the turbocharger according to the instruction manual.

Remove the cover from the top of the funnel.

All items in the “laying-up check list” (as mentioned in paragraph 1) must be brought back to normal service condition prior to start of the engine.

Reference is also made to our instruction manual, particularly the chapters “Check during standstill periods” and “Preparations for starting”.