

Action code: **WHEN CONVENIENT**

**Tightening of chain**  
**L/S70ME-C**

SL09-514/NJC  
August 2009

**Concerns**

MAN B&W two-stroke low speed marine diesel engines.  
Type: L/S70ME-C

**Summary**

Use of hydraulic jacks for chain tightening.

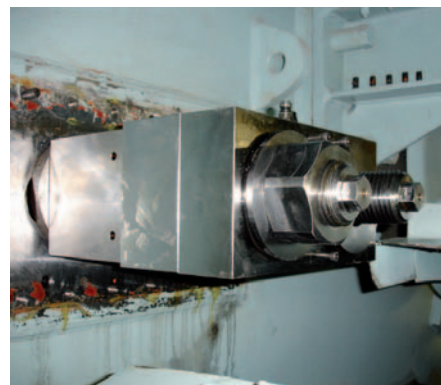

Dear Sirs

It has recently come to our knowledge that tightening of the chain tightener shaft on L/S70ME-C engines has caused some difficulties.

On MAN B&W L/S70ME-C type engines, the chain tightener shaft must be tightened by means of the main bearing hydraulic jacks. However, in some cases the hydraulic jacks for the exhaust valve have mistakenly been used for this task.

Tightening of the chain tightener shaft is NOT to be carried out by means of the hydraulic jacks for the exhaust valve, as the tightening force of these jacks is only approx. 2/3 of the force necessary.

This service letter specifies the correct procedure for use of the chain tightener tool on L/S70ME-C engines.

Yours faithfully



**Mikael C Jensen**  
Vice President,  
Engineering



**Niels B Clausen**  
Senior Manager,  
Engine and System Application

Encl.:  
Procedure M90602  
Data D10602

**Head office (& postal address)**  
**MAN Diesel**  
Tegholmegade 41  
2450 Copenhagen SV  
Denmark  
Phone: +45 33 85 11 00  
Fax: +45 33 85 10 30  
mandiesel-cph@mandiesel.com  
www.mandiesel.com

**PrimeServ**  
Tegholmegade 41  
2450 Copenhagen SV  
Denmark  
Phone: +45 33 85 11 00  
Fax: +45 33 85 10 49  
PrimeServ-cph@mandiesel.com

**Production**  
Tegholmegade 35  
2450 Copenhagen SV  
Denmark  
Phone: +45 33 85 11 00  
Fax: +45 33 85 10 17  
manufacturing-dk@mandiesel.com

**Forwarding & Receiving**  
Tegholmegade 35  
2450 Copenhagen SV  
Denmark  
Phone: +45 33 85 11 00  
Fax: +45 33 85 10 16

**MAN Diesel**  
Branch of MAN Diesel SE, Germany  
CVR No.: 31611792  
Head office: Tegholmegade 41  
2450 Copenhagen SV, Denmark  
German Reg.No.: HRB 22056  
Amtsgericht Augsburg

To be able to tighten the chain tightener shaft correctly, using the hydraulic jacks for main bearings, it is very important to ensure a distance of 155 mm (+2/-0 mm) from the chain tightener stud ends to the aftmost surface of the frame box, see Fig. 1.

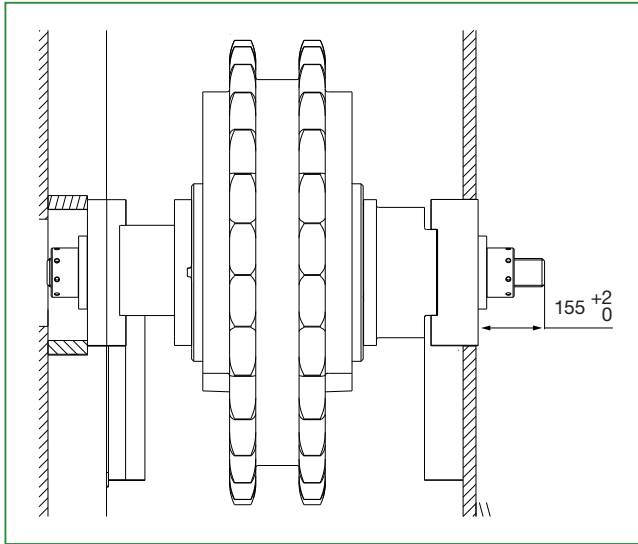

Fig. 1

If the distance exceeds 157 mm, adjust the distance to 155 mm by turning the nuts in the opposite end of the chain tightener studs.

However, if the distance from the ends of the chain tightener studs and the aftmost end of the frame box is 162-165 mm or more, it is likely that the hydraulic jacks for the exhaust valve were used for tightening of the chain tightener shaft. In such a case, these jacks must also be used for loosening the chain tightener shaft again.

Using the main bearing hydraulic jacks when the distance measures 162-165 mm or more involves a risk of the conical part of the extension stud interfering with the lower part of the hydraulic jack housing/cylinder block, see Fig. 2.

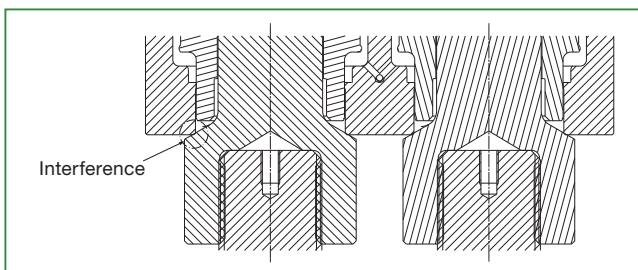

Fig. 2

Before re-tightening the chain tightener shaft by means of the main bearing hydraulic jacks, re-adjust the distance from the chain tightener stud ends to the aftmost end of the frame box to 155 mm (+2/-0 mm), see Fig. 3.

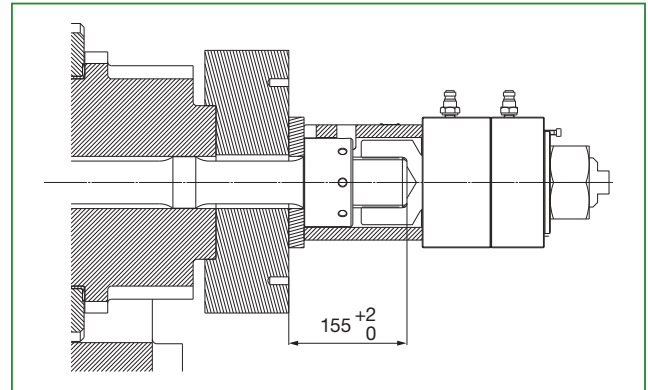

Fig. 3

For your information we enclose MAN B&W procedure M90602, Ed. 0253, Chain Tightener, Adjustment.

For further advice or clarification, you are welcome to contact our Maintenance, Tools and Procedures department (e-mail: [lee3@mandiesel.com](mailto:lee3@mandiesel.com)).

1. Turn the engine in the AHEAD direction.

Remove the chain tightener cover.

Assemble and fit the tightening tool studs **B** in the threaded holes in the tightener wheel shaft. This is done through the opening **C**. Fit the chain tightener tool hydraulic jacks on the studs as shown in **D**. This is to keep the chain tightener in place.

2. Install the hydraulic jack on the chain tightener using a tackle and three eyebolts screwed into the threaded holes in the hydraulic jack parts.
3. Check measurement D06-68. If necessary, adjust according to the value stated in the data sheet.

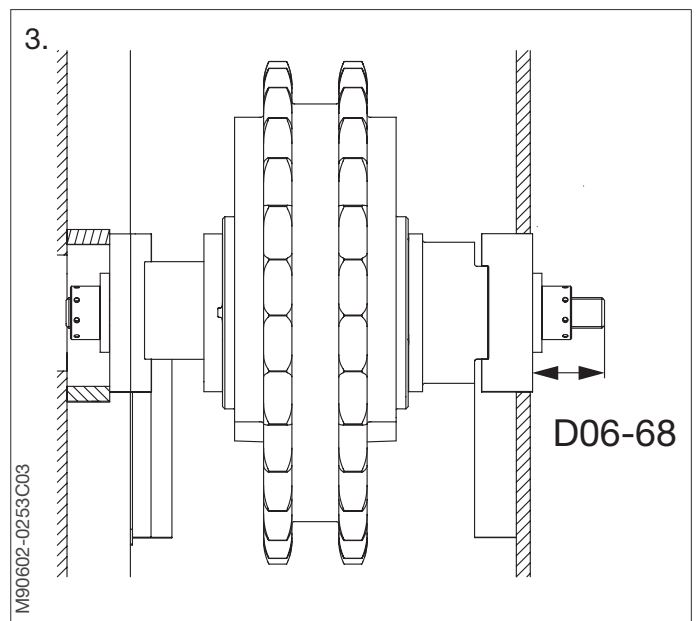
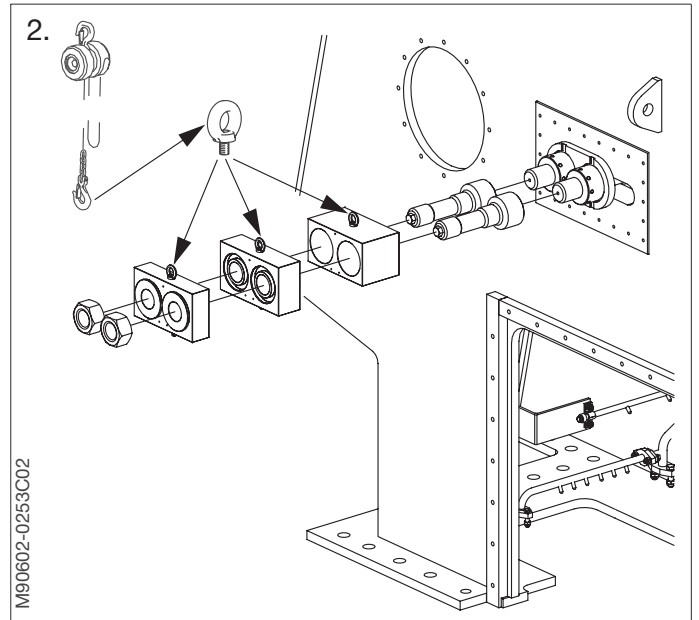
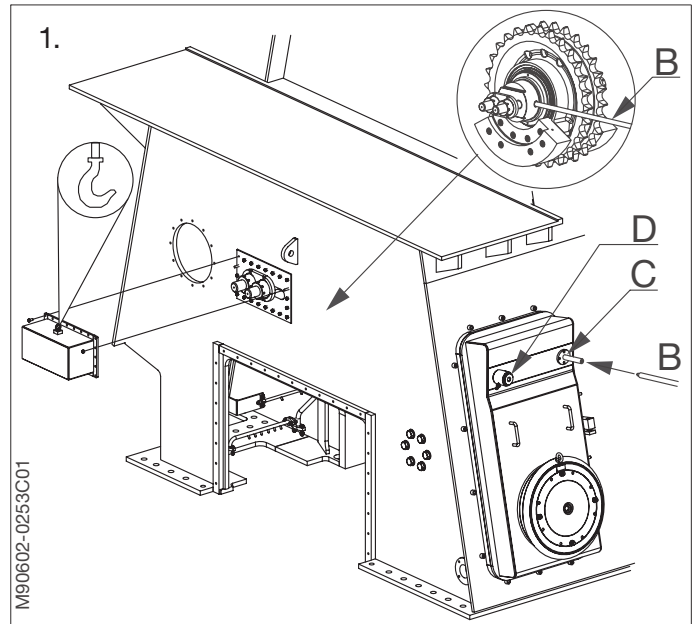

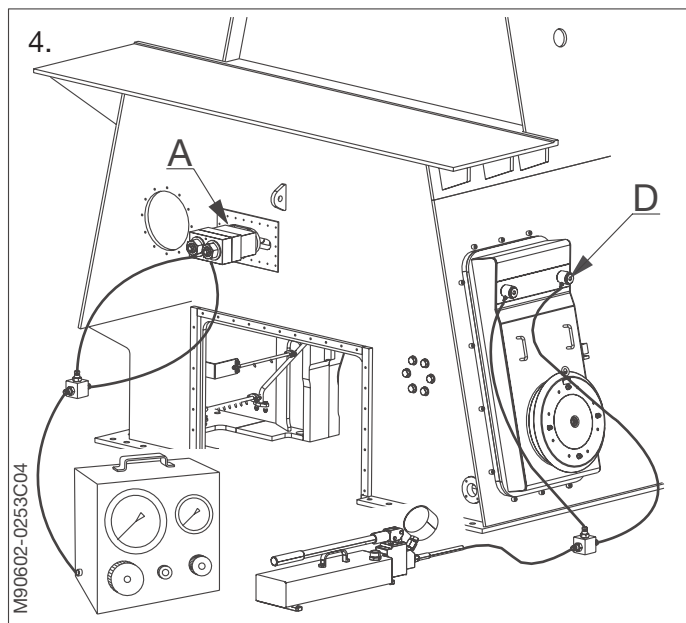

4. Loosen the hydraulic nuts **A** on the fore side of the chain tightener wheel.  
*For operation of the hydraulic tools, see Procedure 913-1.*

Tighten the hydraulic jacks **D** simultaneously to the value stated in Data D13-01.

Use the hand operated hydraulic pump for this operation.

Tighten the hydraulic nuts **A** to the value stated in Data D13-01. Use the hydraulic pump for this operation.

Loosen the hydraulic chain tightener tools and remove the tools from the engine.

**SAFETY PRECAUTIONS** *For detailed sketch, see 900-2*

<input checked="" type="checkbox"/>	Stopped engine
<input checked="" type="checkbox"/>	Shut off starting air supply – <i>At starting air receiver</i>
<input checked="" type="checkbox"/>	Block the main starting valve
<input checked="" type="checkbox"/>	Shut off starting air distributor/distributing system supply
<input checked="" type="checkbox"/>	Shut off safety air supply – <i>Not ME engines</i>
<input checked="" type="checkbox"/>	Shut off control air supply
<input type="checkbox"/>	Shut off air supply to exhaust valve – <i>Only with stopped lubricating oil pumps</i>
<input checked="" type="checkbox"/>	Engage turning gear
<input type="checkbox"/>	Shut off cooling water
<input type="checkbox"/>	Shut off fuel oil
<input checked="" type="checkbox"/>	Stop lubricating oil supply
<input type="checkbox"/>	Lock the turbocharger rotors

**Data**

Ref.	Description	Value	Unit
D13-01	Hydraulic pressure, mounting	1500	bar
D13-02	Hydraulic pressure, dismantling	1400-1650	bar
D06-68	Max. distance measurement	155-157	mm

The task-specific tools used in this procedure are shown on the plates at the end of this chapter or in the chapters indicated by the first three digits in the plate number, e.g. P90951 refers to chapter 909.

Plate	Item No.	Description
P90561		Main bearing - hydraulic tools
P90671		Hydraulic tools - chain tightener
P91351	010	Hydraulic pump, pneumatically operated
P91351	022	Hydraulic pump, hand operated
P91351	046	Hose with unions (1500 mm), complete
P91351	058	Hose with unions (3000 mm), complete
P91351	105	3-way distributor block, complete
P91351	117	5-way distributor block, complete