

Action code: AT FIRST OPPORTUNITY

Replacement of Transparent Polycarbonate Covers

SL2012-558/CHL

March 2012

Concerns

Owners and operators of MAN B&W two-stroke marine diesel engines.
Type: MC/MC-C and ME-B

Summary

For reasons of staff safety in the event of an engine room fire, we recommend replacing transparent polycarbonate covers with non-transparent covers made of steel.

Dear Sirs

In recent years we have seen a rising number of engines in service with transparent covers of polycarbonate on the camshaft housing, as requested by the shipowner.

As the focus on safety is presently an increasing trend in the market, we have re-evaluated the justification of these covers in cooperation with the engine builders.

According to our evaluation, it is inadvisable to install transparent covers due to the increased risk for the staff in the unlikely event of an engine room fire or crankcase explosion.

For reasons of safety, we therefore recommend you to replace transparent covers made of polycarbonate.

For purchase of new covers in accordance with our recommendation, please contact:

- Your engine builder or
- MAN Diesel Primeserv at: Primeserv-cph@mandieselturbo.com

Questions or comments regarding this SL should be directed to our Dept. LEE1 (e-mail: LEE1@mandieselturbo.com)

Yours faithfully



Mikael C Jensen
Vice President,
Engineering



Niels B Clausen
Senior Manager,
Engine and System Application

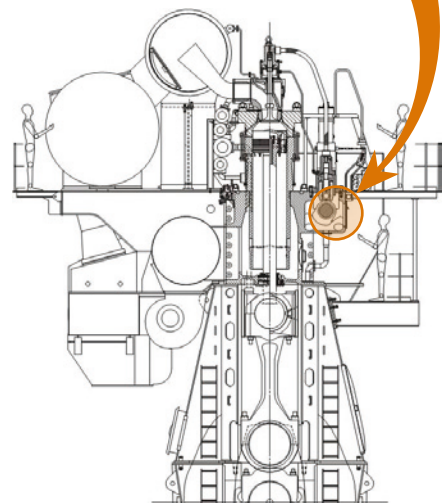
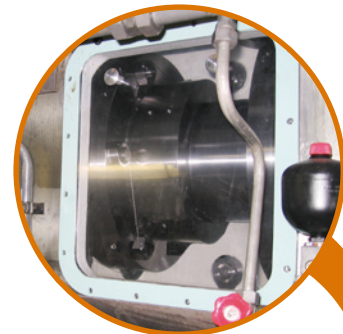

Head office (& postal address)
MAN Diesel & Turbo
Tegholmsholmsgade 41
2450 Copenhagen SV
Denmark
Phone: +45 33 85 11 00
Fax: +45 33 85 10 30
info-cph@mandieselturbo.com
www.mandieselturbo.com

PrimeServ
Tegholmsholmsgade 41
2450 Copenhagen SV
Denmark
Phone: +45 33 85 11 00
Fax: +45 33 85 10 49
Primeserv-cph@mandieselturbo.com

Production
Tegholmsholmsgade 35
2450 Copenhagen SV
Denmark
Phone: +45 33 85 11 00
Fax: +45 33 85 10 17
manufacturing-dk@mandieselturbo.com

Forwarding & Receiving
Tegholmsholmsgade 35
2450 Copenhagen SV
Denmark
Phone: +45 33 85 11 00
Fax: +45 33 85 10 16
shipping-cph@mandieselturbo.com

MAN Diesel & Turbo
Branch of MAN Diesel & Turbo SE,
Germany
CVR No.: 31611792
Head office: Tegholmsholmsgade 41
2450 Copenhagen SV, Denmark
German Reg.No.: HRB 22056
Amtsgericht Augsburg