

Action code: AT FIRST OPPORTUNITY

**Starting Air System**

Main engine

SL2018-668/KNB

December 2018

**Concerns**

Owners and operators of MAN B&W two-stroke marine diesel engines. Type: MC/MC-C and ME/ME-C

**Summary**

Correct maintenance of starting air system to avoid any ruptures

Dear Sir or Madam

We have recently received reports of malfunctioning starting air systems that led to rupture of the starting air manifold. Based on our findings in these cases we would like to emphasise the importance of correct and timely overhaul of the starting air system and of the main engine in order to minimise the risk of suffering personal injuries or causing damage to the engine. Correct and timely maintenance is to be carried out according to the instruction manual delivered with the engine.

Please direct any inquiries and questions regarding the content of this Service Letter to our:

Operation Department at: LEO@man-es.com.

Yours faithfully



**Mikael Jensen**  
Vice President  
Engineering



**Stig B. Jakobsen**  
Senior Manager  
Operation



Ruptured starting air manifold



Blind flange at fore-end of the starting air manifold

**Head office (& po. address) PrimeServ  
MAN Energy Solutions**

Tegholmsholmsgade 41  
2450 Copenhagen SV  
Denmark  
Phone: +45 33 85 11 00  
Fax: +45 33 85 10 30  
info-cph@mandieselturbo.com  
www.man-es.com

Tegholmsholmsgade 41  
2450 Copenhagen SV  
Denmark  
Phone: +45 33 85 11 00  
Fax: +45 33 85 10 49  
PrimeServ-cph@mandieselturbo.com

**Production**

Tegholmsholmsgade 35  
2450 Copenhagen SV  
Denmark  
Phone: +45 33 85 11 00  
Fax: +45 33 85 10 17  
manufacturing-dk@mandieselturbo.com

**Forwarding & Receiving**

Tegholmsholmsgade 35  
2450 Copenhagen SV  
Denmark  
Phone: +45 33 85 11 00  
Fax: +45 33 85 10 16  
shipping-cph@mandieselturbo.com

**MAN Diesel & Turbo**

Branch of MAN Energy Solutions  
SE, Germany  
CVR No.: 31611792  
Head office: Tegholmsholmsgade 41  
2450 Copenhagen SV, Denmark  
German Reg.No.: HRB 22056  
Amtsgericht Augsburg

**Normal engine operation**

The bursting disc at the starting air valve in the pipe branch for the cylinder cover is designed to withstand the 30 bar starting air pressure but will rupture in case of a significantly higher pressure and in this way protect the starting air manifold, non-return valve and main starting valve.

A hissing sound inside the bursting cap will indicate that a bursting disc has ruptured.

Normally, only a single bursting disc will be found ruptured, and the branch pipe as well as the starting air valve will have been heated up by the combustion gas-

ses with discoloration of the paint as a consequence. A possible reason for a rupture of a bursting disc can be a “hanging starting air valve” – leading the combustion pressure back through the starting air valve towards the starting air manifold.

Normal daily operation of the main engine and scheduled proper maintenance will limit incidents of ruptured bursting discs at the starting air valve in the pipe branch for the cylinder cover.

The bursting disc must be exchanged and the starting air valve must be overhauled at the earliest opportunity if the bursting disc has ruptured.

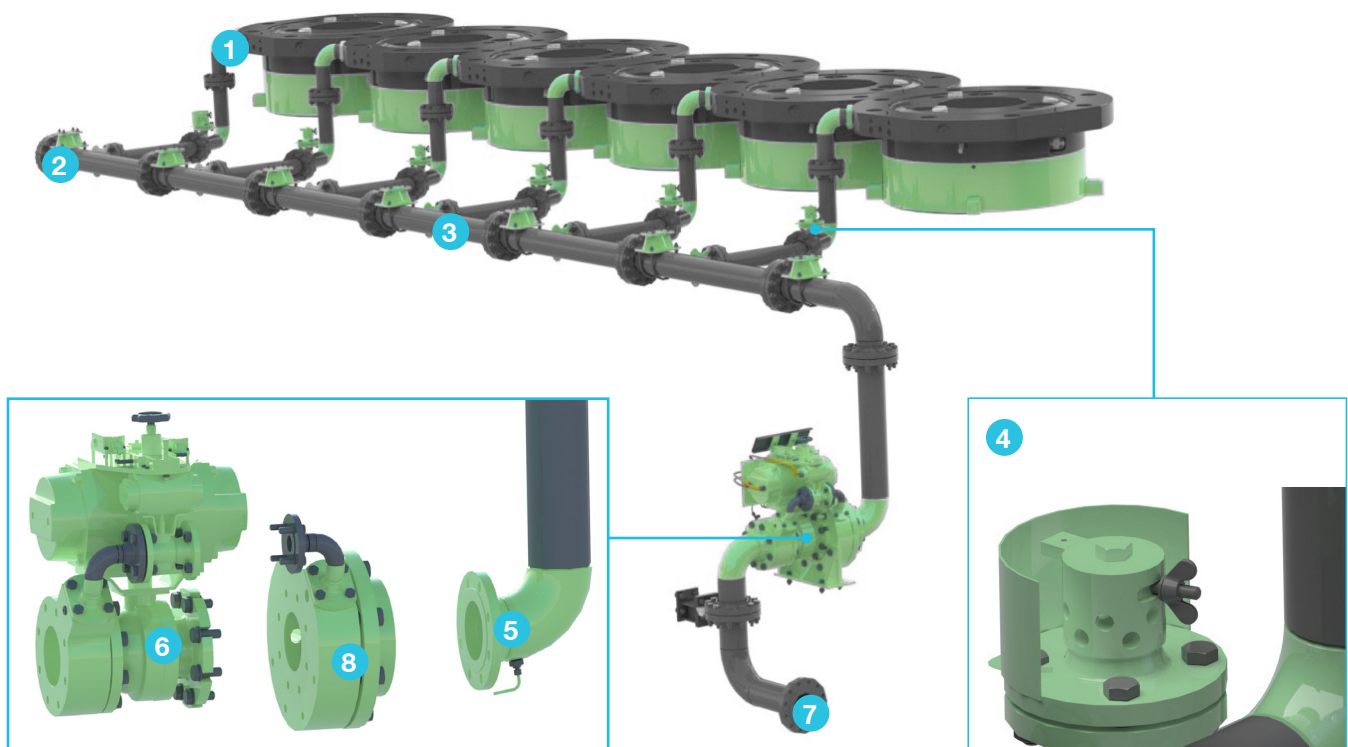

- 1. Starting air valve
- 2. Drain/venting pipe
- 3. Starting air manifold
- 4. Bursting cap and bursting disc
- 5. Drain/venting pipe
- 6. Main starting valve
- 7. Starting air supply
- 8. Non-return valve



Fig. 1 Starting air system

**Explosion in the starting air system**

In the worst case an explosion in a starting air manifold may lead to rupture of the manifold. Such incidents pose a serious potential threat to property and persons, and may even result in bodily injuries and/or fatal casualties. Proper and timely maintenance can prevent such incidents.

In order for a combustion to take place in the starting air system, a combustible mixture must be present inside the starting air manifold.

The starting air manifold is designed in such a way that any fluid will be drained out of the open drains by gravity in both ends, to prevent any combustion from taking place inside the starting air system.

If the drains are blocked, a combustible mixture may be trapped inside the manifold or the branch pipes and thus become a hazard, see Fig. 4.

**Open drain pipes (gravity drain)**

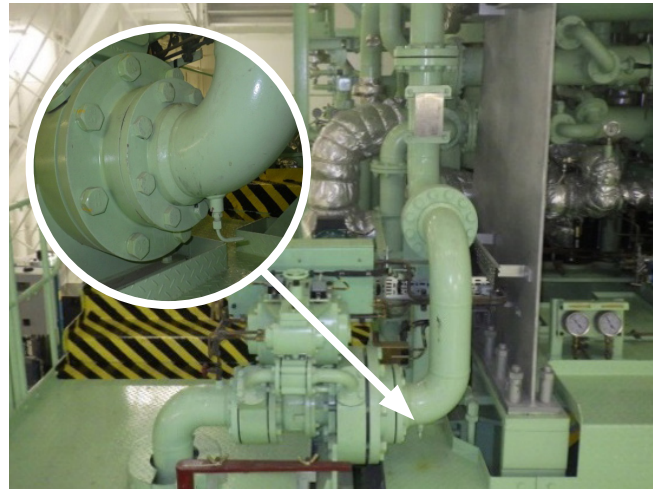

Fig. 2: Main starting air valve



Fig. 3: Drain/venting pipe at starting air manifold at blind end (lowest point of starting air manifold).

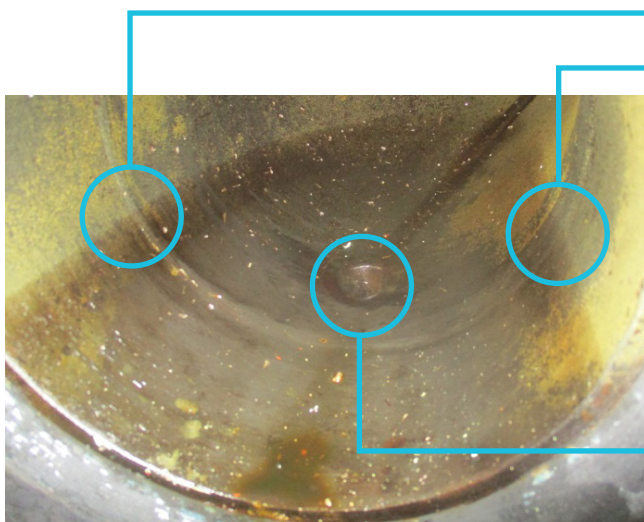

Fig. 4: Starting air pipe bend after main starting air valve towards engine

Clear evidence that an oily substance has been present inside the starting air pipe bend next to the main starting valve (ball valve) at the lowest point of the starting air manifold.

Hole for gravity drain, which has been blocked and is thus not working correctly.

The most likely reason for the unintended combustible mixtures can be one of the below or a combination:

– **Oil leakage from the compressor arrangement**

Air bottles are normally drained automatically, for which reason the ship crew will not be able to determine if the drain consists of water or a mixture of water and oil.

If an oily substance is present, the origin of the substance must be found and remedied as soon as possible.

– **Fuel oil leakage from the cylinder cover**

Fuel leakages from components near the drain groove on the top of the cylinder cover.

Any fuel leakage from fuel valves or pipings on the cylinder cover must be remedied as soon as possible.

– **Defect O-ring sealing on the starting air valve**

Leakage of combustible fluids may pass through the O-ring sealing on the starting air valve.

In case of a defect O-ring the starting air valve must be overhauled as soon as possible.

The below shown Figure shows an example of an open drain modified in a way that obstructs the intended draining of the manifold by means of gravity. Any kind of modification to the drain pipe is prohibited for safety reasons as modifications may increase the risk of blocking the pipes or create a water-lock in the pipe.

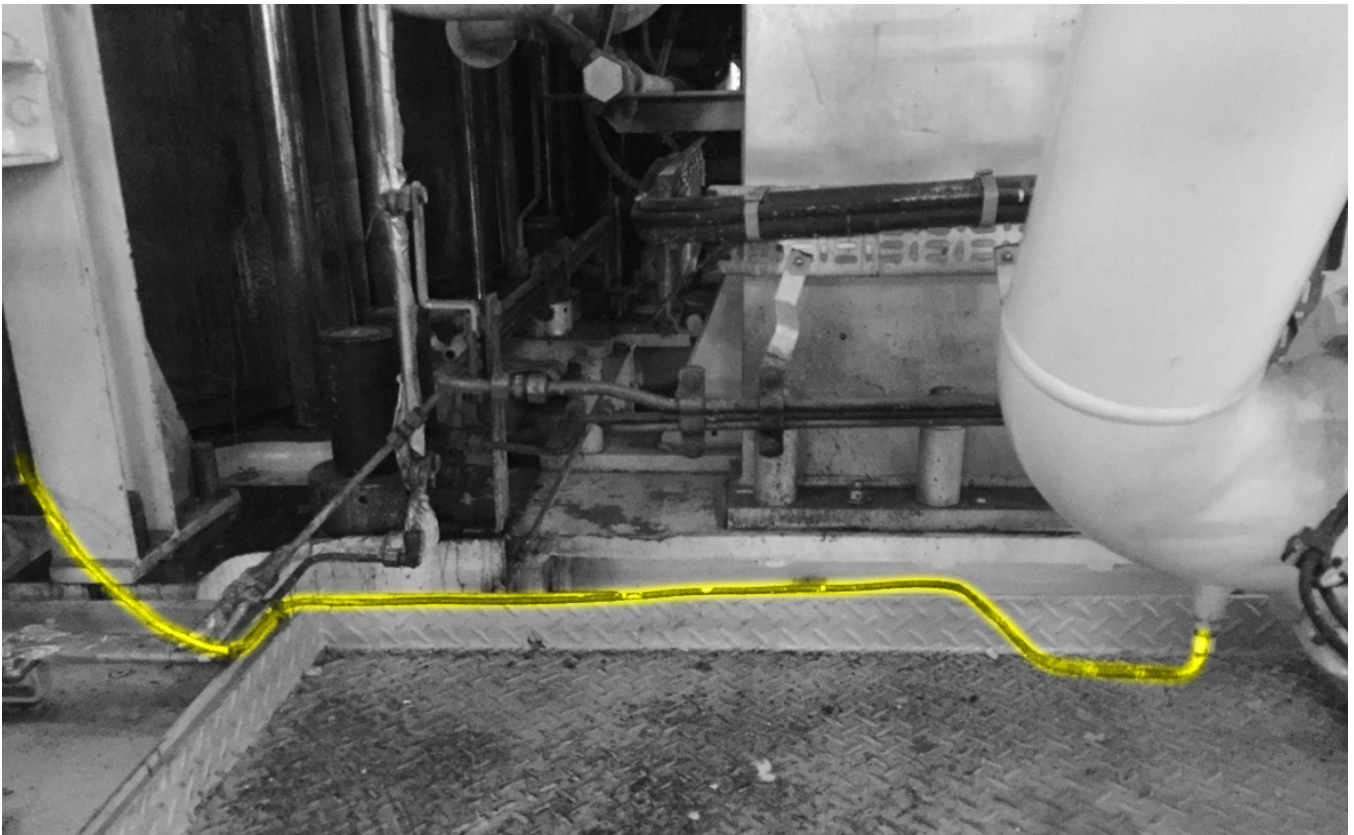

Fig. 5: Example of a modified drain (highlighted in yellow)

**Starting air valve in cylinder cover**

It is important to check the condition of the sealing ring for the starting air valve and exchange it, if needed. We strongly recommend also to change the O-ring to a Fluoro rubber O-ring if the present O-ring is made of silicone rubber, as the Fluoro rubber is a more robust O-ring. O-rings made of silicone rubber may decompose during service and thus not last the expected 12,000 hours as stated in the current Service Letter for guidance overhaul intervals. We recommend that only original Fluoro rubber O-rings are used. The mentioned colours of the O-rings are solely referring to the products delivered or purchased through MAN ES. The colour may deviate for O-rings supplied otherwise. Please contact the supplier (engine maker) to clarify the material.



Fig. 6: Example of an O-ring with no sealing effect in the starting air valve. Please note the light between O-ring and steel ruler, which indicates that there is no sealing effect.

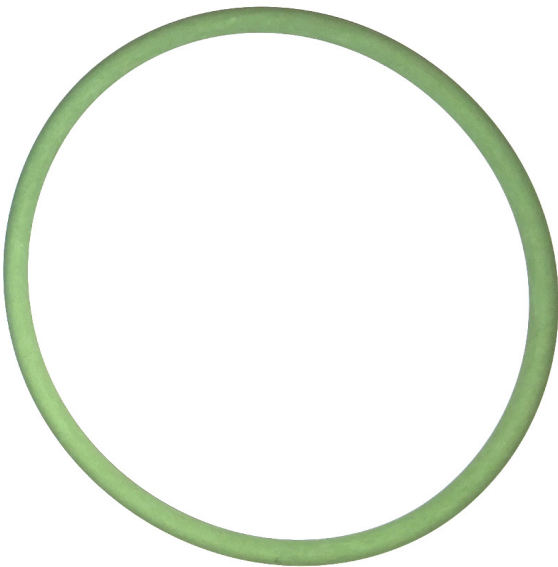

Fig. 7: Fluoro rubber O-ring, green

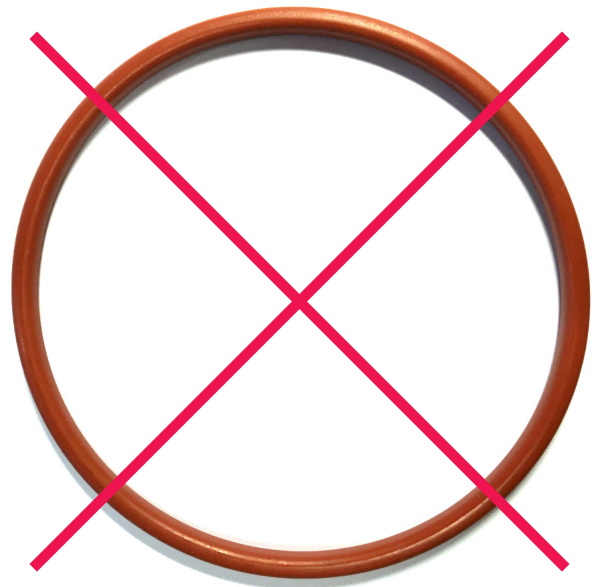

Fig. 8: Silicone rubber O-ring, red (NOT to be used)

**Proposal for regular onboard routine check to prevent failures in the starting air system, as a supplement to normal start-up inspections and procedures:**

- The drain point positioned at the starting air manifold must always be open to ensure free drainage based on gravity.

**At engine start-up**

Immediately after starting the engine, listen for a “hissing sound” from the drain points when venting the starting air manifold from 30 bar pressure to 0.

**At “Finished with engine”**

Visually inspect the area below the drainpipes for water or oily substance. Check by poking a steel rod through the pipe and watch for overpressure and fluids.

Visually inspect for fuel leakage during daily routine watch. Check that the drain from the cylinder cover is open and working properly.

- The condition of the sealing ring on the starting air valve is checked, and it is replaced, if necessary.

**At “Finished with engine”**

The drain groove in the cylinder cover around the starting air valve may be filled with water (only for starting air valves mounted on the top surface of cylinder cover). By gravity, a defective O-ring sealing will drain the water into the starting air valve. Check the water level by a visual inspection after 1 hour. If water is drained into the starting air valve, the O-ring is defective and must be exchanged.

**Before start-up of engine**

The drain groove in the cylinder cover around the starting air valve may be filled with water (only for starting air valves mounted on the top surface of cylinder cover).

During start-up of the engine or during slow turning any air leakage through the O-ring on the starting air valve can easily be detected by observing if any spray of water comes from the leaking O-ring.

The manual drain (normally closed) in the starting air piping between the air bottles and the main engine must be drained regularly, and the content of the drainage must be checked visually for any oily substance.

**Test procedure for checking of external air leakage from starting air valves for MC/MC-C engines**

- Prepare the engine for start.
- The engine control is shifted to manual control at the engine side console.
- The air supply for the starting air distributor is “cut off” on the starting air distributor valve handle.
- 1 person is located at the engine side console.
- At least 1 person is positioned on top of the engine to check for leakages.
- Press the start button on the engine side console and check that the shaft is not rotating.

If the shaft rotates partly, a starting air valve is leaking

- Press the start button and keep it active when the tightness from starting air valves and the complete starting air system has been checked for leakages.

All starting air valves are to be checked for leakages from the sealing in the cylinder cover.

Be aware that there will be a noisy “blow-off” from the drain pipes in each end of the starting air pipe. Ensure that these drains are not blocked or extended. The blow-off pipe must be of original length which is a few cm.

- With open indicator cocks, it can be checked if there are any leakages present from the starting air valves by listening and feeling for any air from the indicator valve.

This test can also be made with the engine in C/R control with good communication lines between the involved persons.

See also General overview of Starting Air System page 7.

General overview of Starting Air System (valid for both MC/-MC-C and ME/ME-C engines)

1. Starting air valve placed vertically in cylinder cover.

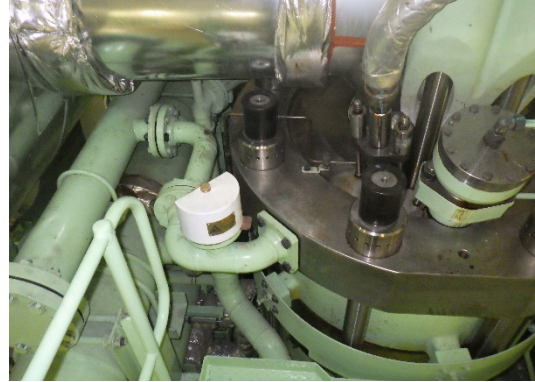

2. Check for air leakage from O-ring sealing between cylinder cover and start valve.



3. Confirm – starting air drainage from drain pipe (fore) without any traces of water/fuel.

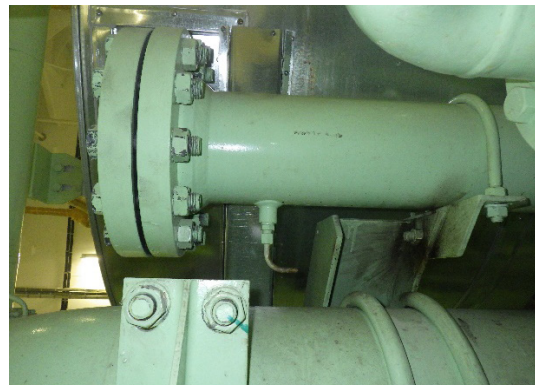

4. Confirm – starting air drainage from aft drain pipe without any traces of water/fuel.



**Note: The engine will turn in case the starting air valve is stuck in (partly) open position.**

**Test procedure for checking of external air leakage from starting air valves for ME/ME-C engines**

This MOP test procedure describes how to pressurise the main starting air pipe with closed starting air valves during engine standstill and stand-by condition, ready to start.

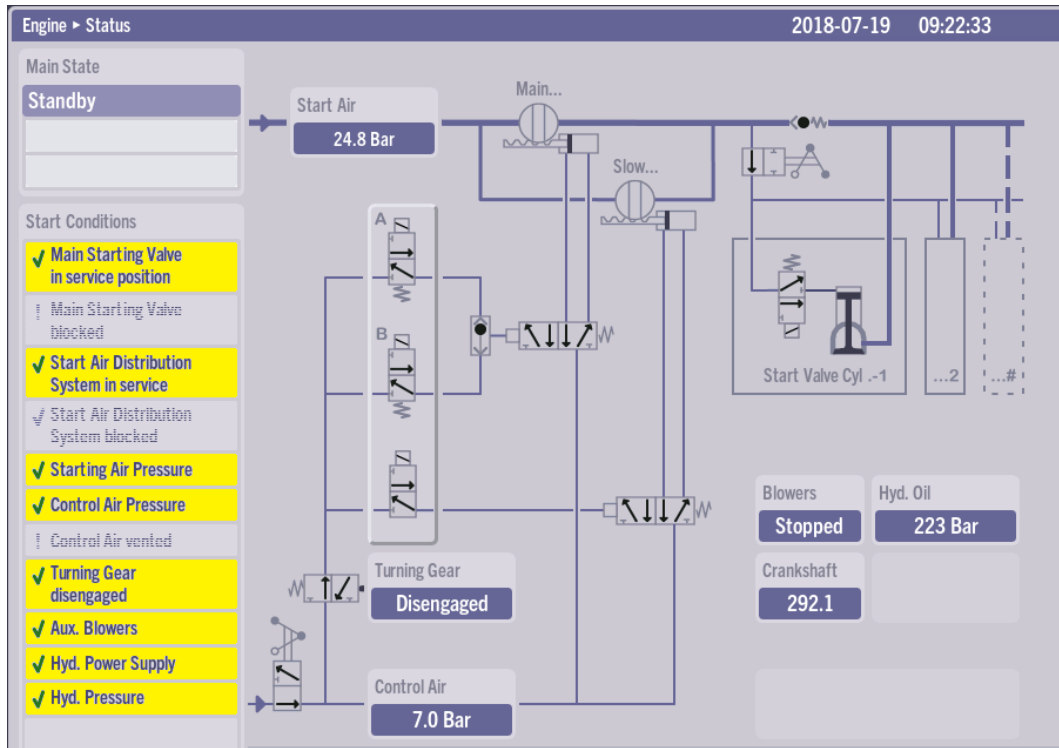

Fig. 9: Engine in standby condition – Ready to start without any start blockings or shutdowns.

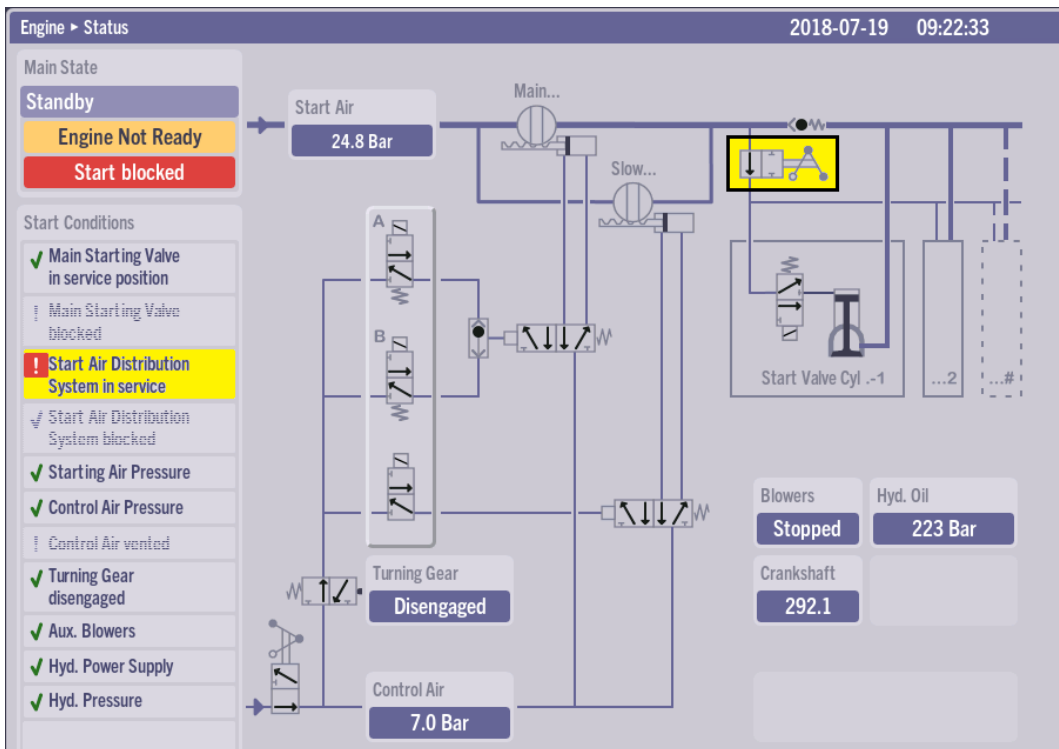

Fig. 10: Close shut-off valve to starting air distributor – Note: Engine Not Ready/Start blocked.



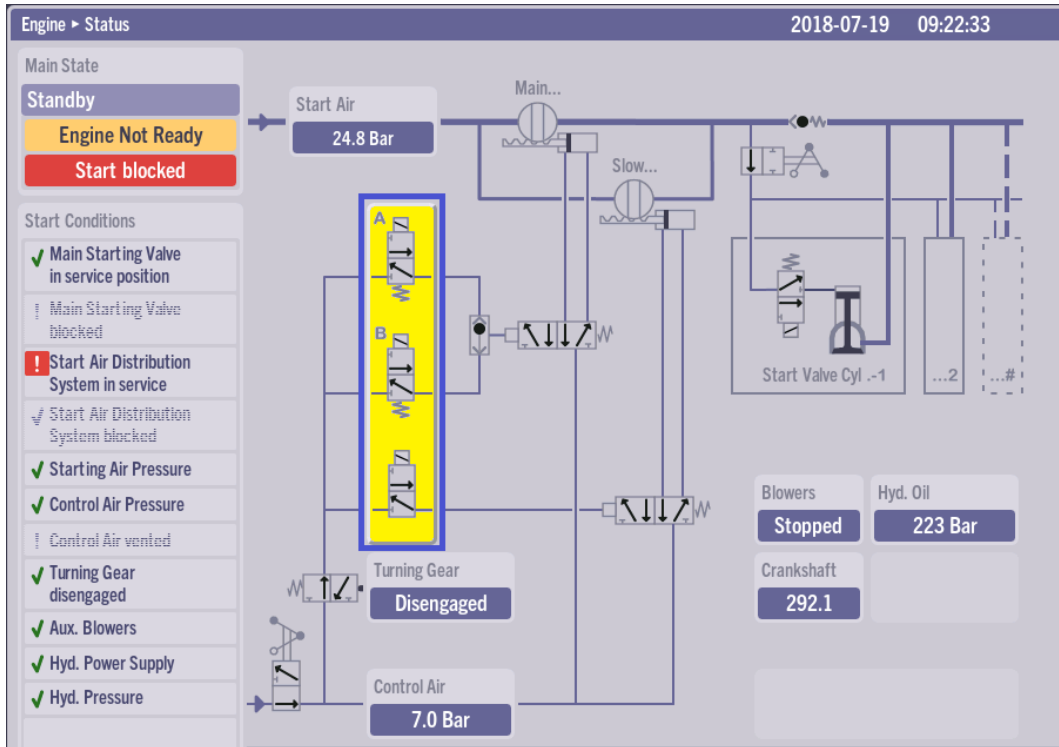

Fig. 11: Select test function of three (3) solenoid valves – marked yellow above.

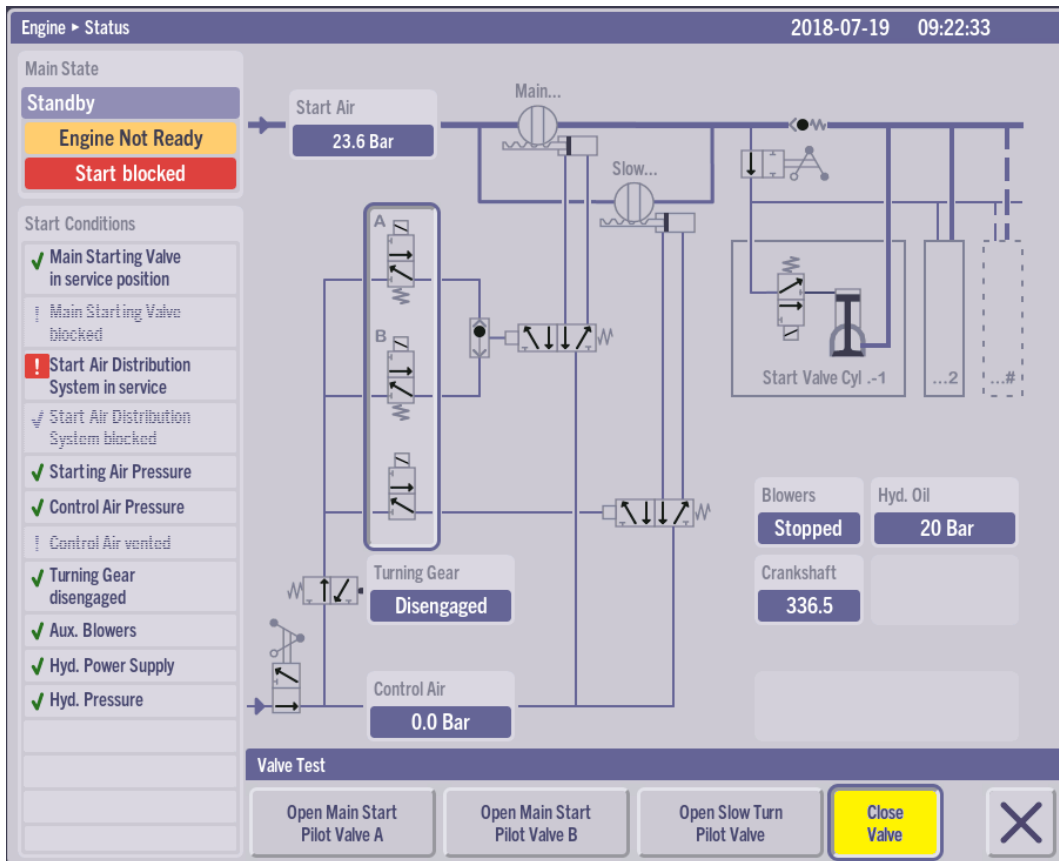

Fig. 12: Valve test function will appear – Note: Close Valve is activated (blue shadow around).

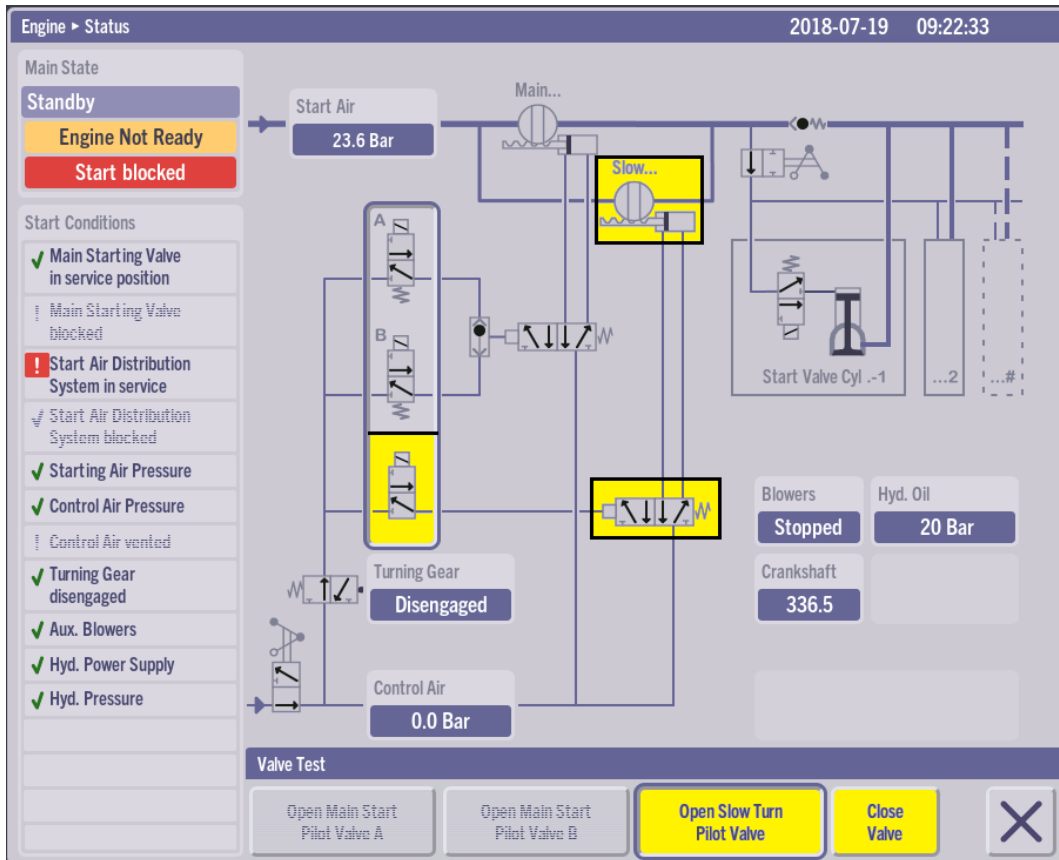

Fig. 13: Test: Open Slow Turn Pilot Valve – Check for external air leakages – Close Valve.

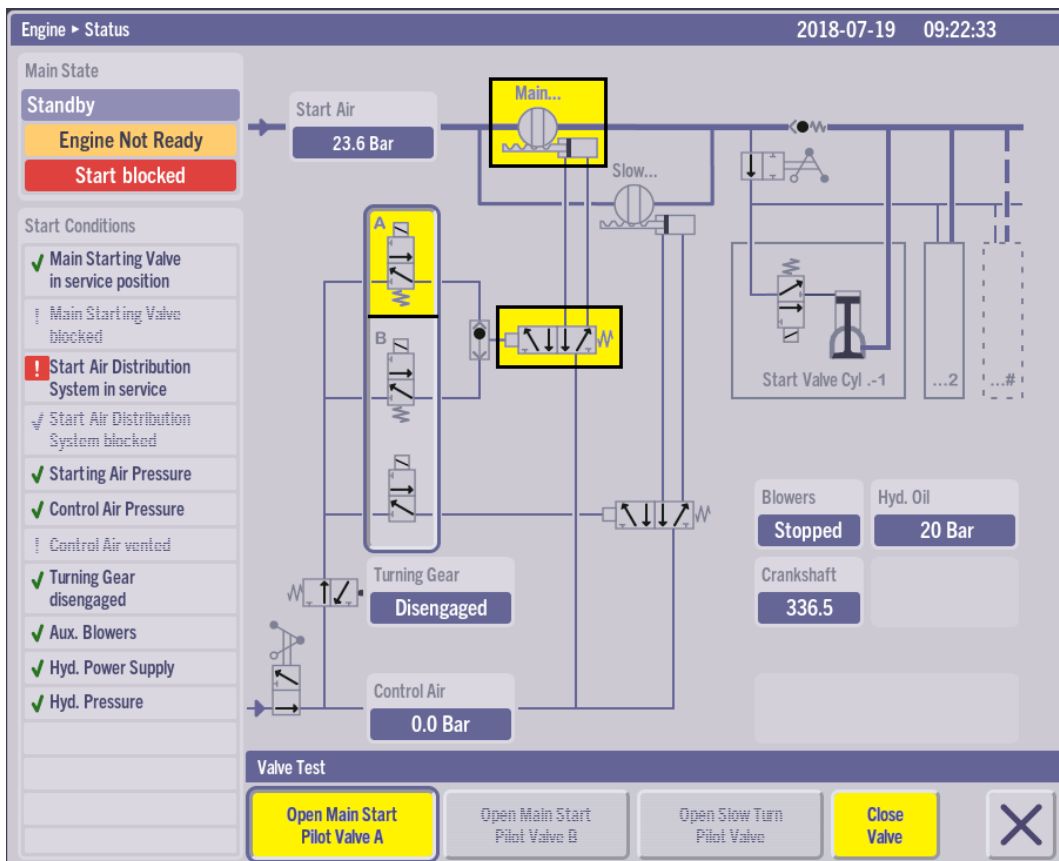

Fig. 14: Test: Open main starting valve (A or B) – Check for external air leakages – Close valve.